

1

THE HARYANA DAIRY COOPERATIVE'S STAFF SERVICE RULES, 1988

C O N T E N T S

<u>Rule No.</u>	<u>Particulars</u>	<u>Page</u>
<u>CHAPTER - I</u>		
<u>Preliminary</u>		
1.	Short Title; Commencement and application.	6 - 7
2.	Definitions.	7 - 10
<u>CHAPTER - II</u>		
<u>Appointments</u>		
3.	Creation of Service, Staff Strength, pay scales, Dearness Allowance.	10-12
4.	Nature of appointments.	12-13
5.	Mode of appointments.	13
6.	Ratio of direct appointment.	13
7.	Appointment by direct recruitment.	14-16
8.	Appointment by transfer.	16
9.	Appointment by deputation.	16-17
10.	Appointment by promotion.	17
11.	Reservation for members of Scheduled Castes/ Scheduled Tribes, Backward Classes, Ex-servicemen and Physically handicapped.	18
12.	Probation.	18-20
13.	Appointing Authority.	20-22
14.	General conditions relating to appointments.	22-25
15.	Training.	25-27
16.	Security.	27
17.	Seniority.	27-29
18.	Joint Seniority, of certain categories.	29-31

19. Confirmation.	31-32
20. Transfers.	32-33

CHAPTER - III

Pay and Allowances

21. Pay.	34
22. Dearness Allowance - City Compensatory allowance.	34
23. House Rent.	34
24. Medical Allowance.	34
25. Travelling Allowance.	34-35
26. Provident Fund.	35
27. Bonus.	35
28. Gratuity.	35
29. Other Allowances.	35-36
30. Uniform & Liveries.	36
31. Financial Liability.	36-37
32. Pay Fixation.	37
33. Annual Increment.	37-38
34. Efficiency Bar.	38
35. Biennial Increments.	38

CHAPTER - IV

Resignation-Retirement-Termination

36. Termination of Service not as a disciplinary measures.	39-40
37. Resignation.	40-41
38. Retirement.	41

For Notice : See Rule 110 of App. Act.

39. Re-employment.	41-42
40. Compulsory Retirement.	42
41. Voluntary Retirement.	42

CHAPTER - V

Casual leave and other leave

42. Type of leave and authorities competent to sanction.	43-47
43. Leave as per Punjab Industrial Establishment (National and Festival Holidays and casual and Sick Leave), Act, 1965.	48

CHAPTER - VI

Conduct and Discipline

44. General.	48-55
45. Moveable, Immoveable and Valuable property.	55-56
46. Minor misconduct and its penalties.	57
47. Major mis-conduct.	57-62
48. Penalties.	62-67
49. Suspension.	68-70
50. Charge-sheet and Appointment of Enquiry Officer.	71
51. Appeal.	71-72
52. Revision.	72

CHAPTER - VII

General

53. Record of Services.	72
54. Annual Confidential Report.	73-75
55. Joining Time on Transfer.	75-76
56. Military Service Benefits.	76

57. Promotion of small family norm.	76
58. Death during service.	76
59. Conveyance Allowance.	76
60. Loan to staff members.	76-77
61. Standing orders.	77
62. L.T.C. Benefits.	77
63. Amendment of Rules.	77-78
64. Relaxation.	78
65. Interpretation of rules.	78
66. Saving.	79
67. Repeal.	79

ANNEXURES

Annexure A.	Categories of post(s) in the service of the Federation.	80-84
Annexure B.	Qualifications and nature of recruitment in the Federation.	85-102
Annexure C.	Categories of posts in the service of a Union.	103-104
Annexure D.	Qualifications and nature of recruitment for a Union.	105-111
Annexure E.	Authorities competent to sanction leave.	112-114
Annexure F-1	Format for A.C.R.	115-123
F-2		
F-3		
F-4		
Annexure G.	Authorities competent to record ACR.	124-131
Annexure H.	Proforma for declaration of Moveable and Immoveable property.	132-133

THE HARYANA DAIRY COOPERATIVE'S STAFF SERVICE RULES 1988

In exercise of the powers conferred on the Board of Directors of Haryana Dairy Development Cooperative Federation Limited under bye law No. 30.2 of the Federation and in exercise of the powers conferred on the Board of Directors of the District Milk Producers Cooperative Unions, under Bye-law No. 21.1 of the Unions, the concerned Board of Directors have accorded their approval to the Staff Service Rules named as "The Haryana Dairy Cooperative Staff Service Rules, 1988 vide their resolutions as under :-

Sr.No.	Name of the Union	Approval Accorded vide <u>Resolution No.</u>	<u>Dated</u>
1.	The Haryana Dairy Development Cooperative Federation Limited, Chandigarh.		
2.	The Ambala District Cooperative Milk Producers Union Limited, Ambala.		
3.	The Bhiwani District Cooperative Milk Producers Union Limited, Bhiwani.		
4.	The Gurgaon Distt. Coop. Milk Producers Union Ltd., Gurgaon.		
5.	The Hissar Distt. Coop. Milk Producers Union Ltd., Hissar.		
6.	The Jind Distt. Coop. Milk Producers Union Ltd., Jind.		
7.	The Karnal Distt. Coop. Milk Producer Union Ltd., Karnal.		
8.	The Kurukshetra Distt. Coop. Milk Producers Union Ltd., Kurukshetra.		

9. The Mohindergarh Distt. Coop. Milk Producers Union Ltd., Narnaul.
10. The Rohtak Distt. Coop. Milk Producers Federation Ltd., Rohtak.
11. The Sirsa Distt. Coop. Milk Producers Union Ltd., Sirsa.

As per above approval the Rules shall read as under :-

CHAPTER - I

Preliminary

Short Title, Commencement and Application.

1.1 Short Title.

These rules shall be called Haryana Dairy Cooperatives, Staff Services Rules, 1988.

1.2 Commencement.

These Rules shall come into force with immediate effect.

1.3 Application.

These Rules shall apply to employees of the Haryana Dairy Development Cooperative Federation Ltd. and those of the District Milk Producers Cooperative Unions which are members of the former and have adopted these rules. Provided that in case of employees whose services are borrowed by the Federation/Cooperative Unions, from any other cooperative - Institution, National Dairy Development Board or Govt., on deputation, these rules shall apply to such an extent as may be specified in the

terms and conditions of deputation agreed upon with the lending authority.

1.4 These rules shall not operate against the provisions of Haryana Cooperative Societies Act, 1984. The Industrial Disputes Act, 1947. The Payment of Gratuity Act, 1972, the minimum wages Act, 1948. The Payment of Bonus Act, Industrial Employment (standing orders) Act, 1946 and such other Central/State Acts as are applicable to Haryana Dairy Development Cooperative Federation Limited and the District Milk Producers Cooperative Unions.

2. Definitions :

2.1 In these rules, unless the context otherwise requires :-

- i) "Federation" means the Haryana Dairy Development Cooperative Federation Limited.
- ii) "Union" means the respective District Milk Producers Cooperative Union which is a member of the Federation.
- iii) "Government" means Government of Haryana.
- iv) "Board" means the Board of Directors of the Haryana Dairy Development Cooperative Federation Ltd. or of the respective District Milk Producers Cooperative Union Ltd., as the case may be.
- v) "Category of Service" means categories of posts as shown in Appendix 'A' and Appendix 'C' in respect

of Federation or a Union respectively.

- vi) "Direct Recruitment" means the appointment made otherwise than by promotion from within the service and also include appointments, made by transfer, by deputation and on adhoc basis.
- vii) "Managing Director" means the Managing Director appointed as such by the Govt. of Haryana under provisions of Haryana Cooperative Societies Act, 1984 but where no such Managing Director is appointed by the Govt. the Managing Director appointed by the Personnel Committee of the Federation.
- viii) "Chief Executive Officer" means Chief Executive Officer of the respective Union by whatsoever designation called.
- ix) "Promotion" means transfer of an employee from one post in a scale of pay to another post in a higher scale of pay which shall not include simple revision of the scale of pay of post held by an employee.
- x) "Employees" includes all salaried persons appointed either on adhoc basis or temporarily or permanently and shall also include persons appointed; as casual workers, apprentice or Probationers.

- xi) "Family" means the employee, spouse, unmarried sons and daughters, widow daughters and parents wholly dependent and residing with the employee.
- xii) "Year" means Cooperative Year from 1st April to 31st March.
- xiii) "Registrar" means the Registrar Cooperative Societies, Haryana.
- xiv) "Basic Pay" means the minimum of the scale plus the amount of increment in that scale granted, if any to an employee at the time of his appointment or subsequently from time to time.
- xvi) "Posts" means the posts specified in Annexure. A & C of these rules.
- xvii) "Personnel Committee" means a committee constituted under Rules 13.1 of the Rules.
- xviii) "Chairman" means the Chairman of the Board/of Directors/Administrators of the Federation or of the respective Union.
- xix) "Management" means the Board, Managing Director of the Haryana Dairy Development Cooperative Federation Limited and includes the General Manager of a Milk Plant Manager SBTC & Manager MEAF and such other nominees as may be authorised in this behalf, in writing by the Managing Director.

The Management for a Union shall mean the Board of the respective union and its Chief Executive Officer or any persons authorised by him in this behalf.

CHAPTER - II

Appointments

3. Creation of Service.

3.1 The posts shown in Annexure A and Annexure C shall be in the service of the Federation and of the concerned Union respectively. Provided that each Union shall have its own service and its employees shall not be transferable to the Federation or to other Unions." Provided that the Federation shall be competent to post, withdraw, transfer Chief Executive Officer and Assistant Accounts Officer of the Milk Unions out of its own service who will be paid by the concerned Union. Provided further that the competent authority under rule 3.3 may provide additional posts/catagories in annexure C for a particular union, having undertaken processing of milk or some other project which is not common with other union.

3.2 Each service shall be classified as below :-

Group A:- Employees carrying basic pay scale of Rs. 2200.00 per month or above.

Group B:- Employees carrying basic pay scale of Rs. 2000.00 per month or above but less than Rs. 2200/-.

Group C:- Employees carrying basic pay scale of Rs. 950/- per month or above but less than Rs. 2000/-.

Group D:- Employees carrying basic pay scale of less than Rs. 950/- per month.

- 3.3 The pay scales admissible to the employees of the Federation and a Union are given in Annexure A & C respectively provided that the Board of the Federation may revise the pay scales with the approval of Registrar as and when required.
- 3.4 The rates of dearness allowance shall be equal to such allowance admissible to Government employees carrying the same pay scales.
- 3.5 The staff strength shall periodically be reviewed by the Board of the Federation and the concerned Union and the concerned Board shall be competent to increase or decrease the strength. Provided that approval of Board of the Federation shall be required to increase the staff strength of a Union.
- 3.6 The Board of the Federation may make cadre review for each service in Annexure A and Annexure C periodically

and may add or delete any category of posts from the respective service.

3.7 The Board of the Federation or the Union, as the case may be, shall be competent to abolish any post(s) and retrench the employees posted against the abolished posts in accordance with the law on the subject.

4. Nature of appointments :

4.1 Appointing Authority may make appointments against the sanctioned vacant post(s) of persons possessing qualifications prescribed in Annexure B & D. Such appointment may be of the nature given below :-

4.1a.Regular : is an employee appointed on a regular basis against a permanent post and confirmed as such.

4.2 Probationer: is an employee provisionally employed to fill a permanent post and is under probation.

4.3 Temporary: is an employee appointed for a limited or specified period of time or for a work of essentially temporary nature or employed in connection with temporary increase in work of permanent nature or an employee awaiting confirmation against a permanent post.

4.4. Casual. is an employee who is employed for any work of casual nature on daily wages.

4.5 Apprentice is an employee engaged for training in a job, trade or craft for a specified period and irrespective of understanding or not of his subsequent absorption in the service.

4.6 Adhoc. is an employee appointed for a period of 89 days at a time but not exceeding 210 days over a period of year from the date of initial appointment against a vacant post as a measure of interim arrangements.

5. Mode of Appointments.

5.1 Appointment to various posts of the service may be :-

- i) By direct recruitment.
- ii) By promotion from a lower post.
- iii) By transfer from other Cooperative Institutions, Government or National Dairy Development Board.
- iv) By deputation of a person from cooperative Institution Government or National Dairy Development Board.

6. Ratio for direct recruitment :

6.1 The ratio of direct recruitment to that by promotion shall be as given in annexure B&D.

Provided that recruitment shall be so regulated that the total number of appointees by direct recruitment in a

category of service including those recruited earlier shall not exceed the ratio given in Appendix B & D. Provided further that direct appointment shall also include appointments made on adhoc basis by transfer and on deputation from other services and appointments by promotion shall mean appointments by promotion from out of the eligible category in the service of the Federation or Union as the case may be.

7. By Direct recruitment.

7.1 Save as provided in Rule 7.2, all direct appointments shall be made out of candidates sponsored by Employment Exchange as per Govt. instructions.

Provided that where recruitment is required to be made from open market the appointments may also be made out of candidates having applied against proper advertisement in atleast one daily newspaper. Provided further that the concerned Board may appoint an Expert on contract for a specific work and for a specific period without reference to Employment Exchange or advertisement in a daily Newspaper.

Próvided further that the concerned Board may reserve some posts meant for direct recruitment to be filled out of existing employees of the Federation and of Union and in such a case, the vacancy (S) shall be circulated to all concerned.

7.2 Where the exigencies of service so require, adhoc appointments on a fixed pay or in regular pay scale or on daily wages may be made upto a period of 89 days at a time subject to a maximum of 210 days over a period of 12 months from the date of first appointment without reference to Employment Exchange or advertisement in a daily newspaper.

7.3 It shall be obligatory on the part of appointing authority to maintain complete record of candidates having been interviewed and their merit.

7.4 The appointing authority may prepare a waiting list upto 25% of the sanctioned strength which shall remain valid upto one year from the date of selection.

7.5 The appointing authority shall fix the order of merit in the decisions of selection and the appointment to the post(s) shall be made in order of merit in the selection list.

8. By transfer.

8.1 The appointing authority may make appointments against a vacant sanctioned post by transfer of an employee holding a substantial/regular post carrying the identical pay scale and similar nature of duties from other cooperative institutions, Govt. or National Dairy Development Board, provided he fulfills qualifications prescribed for the direct recruitment to the post.

9. By deputation.

9.1 The appointing authority may make appointments against a vacant sanctioned post by borrowing the services of an employee holding a similar post in another Cooperative Institution, National Dairy Dev. Board or Govt. for a specific period. The

employee so appointed shall be deemed to have been relieved, on the expiry of the period of deputaion unless such period is further extended by mutual consent.

10. By Promotions.

10.1 The Appointing authority may make promotions from lower post(s) to higher post(s) in the manner prescribed in Annexure B & D.

Provided that promotion of employees in Group D in Annexure B shall be made as per seniority of employees at the level of respective Milk Plant or Semen Bank-cum-Traning Centre, Rohtak or Model Exotic Animal Farm, Bhiwani or Head Office of the Federation including sale points as the case may be.

10.2 The promotion shall be made on the basis of seniority-cum-merit and no employee shall have the right to promotion by virtue of seniority alone.

10.3 The appointing authority shall be guided by past performance, qaulification, both academic and professional and length of service of the employee in that category.

11. Reservation for Scheduled Castes/Scheduled Tribes, Backward Class, Ex-Servicemen/Handicaps.

11.1 The reservation of posts for members of Scheduled Castes/Tribes, Backward Classes, Ex-servicemen and physically handicapped both in direct recruitment and promotion shall be the same as per instructions applicable to Govt. employees.

12. Probation.

12.1

*Amended
vide Resolution
no. 9/161/2011
See page 256.*

Persons appointed to any post in Group-A and B of the service shall remain on probation for a period of two years and in Group C and Group D of the service for a period of 6 months if appointed by direct appointment and one year if appointed by promotion.

Provided that :-

- a) Any period spent on deputation on a corresponding or a higher post(s) after appointment in the service shall count towards period of probation.
- b) Any period of work in equivalent or higher rank, prior to the appointment to the service may, in the case of an appointment by transfer, at the discretion of the appointing authority be allowed to count towards the period of probation.

- c) Any period of officiating appointment shall be reckoned as period spent on probation.

12.2 If in the opinion of the appointing authority, the work and conduct of a persons during the period of probation is not satisfactory, it may :-

- a) If such person is appointed by direct appointment, dispense with ^{his} services; and
- b) If such person is appointed otherwise than by direct recruitment.
- i) revert back to his former post; or
- ii) deal with him in such other manner as the terms and conditions of his appointment permit.

12.3 On the completion of the period of probation of a person, the appointing authority may :-

- a) If his work and conduct has, in its opinion been satisfactory, declare that he has completed his probation satisfactorily. or not
- b) If his work and conduct in its opinion/ been satisfactory - dispense with his services, if appointed by direct appointment, revert him to his former post if appointed by promotion or deal with him

in such other manner as the terms and conditions of his appointment permit if appointed by transfer or

- c) In case of Group A and Group B of the Service extend the period of probation and thereafter pass such order, as could be passed on the expiry of the first period of probation.

Provided that the period of probation shall not be extended by more than one year.

Provided further that the requisite order under this Rule shall be passed within 2 months of the date of completion of the probation.

13

Appointing Authority

13.1

The Board of Directors of the Federation and that of each Union shall constitute a Personnel Committee to perform the functions assigned to it under these rules and the said committee shall comprise of :-

- a) In case of Federation:
- i) Chairman of the Board of the Federation.
- ii) One Director to be nominated by Government out of Government nominee and RCS.
- iii) One Director representing NDDB.

- iv) One non-official elected Director nominated by the Board.
- v) Managing Director.
- b) In Case of Union
- i) Chairman of the Board of the respective Union.
- ii) One Director representing Federation.
- iii) One Director representing - National Dairy Development Board.
- iv) One non-official elected Director nominated by Board.
- v) Chief Executive Officer of the respective union.
- c) Three members shall form quorum for the meetings of the personnel committee.
- d) The functions of the personnel committee shall be performed by the Administrator(s) where no Board exists.

13.2 The following shall be competent to make appointments to the service :-

- A) Posts in Annexure A in the service of the Federation.
- i) General Manager Posts in Group D in the Milk Plant. respective Milk Plant.
- ii) Manager SBTC Posts in Group D in S.B.T.C. Rohtak.

The Haryana Dairy Development Cooperative Federation Limited,
Chandigarh

Ref.No. Estt/Mgr(P&A)/Ser. Rules/91/2125-36 Dt: 21-5-91

To

1. The General Manager,
Milk Plant,
Ambala/Bhiwani/Ballabgarh/Jind/Rohtak & Sirsa
2. Incharge,
Model Exotic Animal Farm,
Bhiwani
3. The Manager,
Semen Bank cum Training Centre,
Rohtak
4. All Sales Depot, Delhi/Chandigarh/Calcutta
5. All Officers at Hqrs.,
Chandigarh.

Sub: First amendment in Haryana Dairy Cooperative Staff
Service Rules, 1988.

- - -

Dear Sir,

In accordance with the decision of the BOD of the HDDCF taken vide their Resolution No.1349/80/91 in its 80th meeting held on 2.5.1991 the existing rule 13.2(iv & v) is hereby substituted by the following sub rule :-

"Managing Director would be the appointing authority of posts in Group A, B, C & D except posts mentioned at (i), (ii) and (iii) above.

Below Rule 13.1(a) and above 13.1(b), the following

shall be added :-

13.1(a) Functions of the Personnel Committee.

- a) Review of staff strength, organisational charts, creation of new posts & abolition of posts.
- b) Selection of officers on direct recruitment on posts under Group A & B but where the Board makes a request to any outside agency such as the HDEB to select personnel, there will be no need to get such selection approved from the Personnel Committee. However, the Personnel Committee may further constitute a Committee which may have outside

Experts for helping in making the selection of suitable officers.

- ✓ c) To recommend giving of productivity linked incentive to the employees.
- d) To recommend award of major punishment to officers of Group A & B.

The amendment of Rules would be effective from 2.5.91 i.e. from the date of decision by the Board. A copy of this letter may be displayed on the Notice Board for information of all employees.

Yours faithfully,

G Sharma

Chief Admn. Officer,
for Managing Director

Endstt. No. Estt/Mgr(P&A)/Ser.Rules/91/2137-46 dt: 21-5-91

A copy is forwarded for information and necessary action to :-

1. All Chief Executive Officers, Milk Unions in the State of Haryana (3 copies each)
2. All Dealing Assistants in Admn, Estt. and Legal branches at H.O. Chandigarh
3. NOTICE BOARD.

G Sharma

Chief Admn. Officer,
for Managing Director

- iii) Manager MEAF. Posts in Group D in MEAF.

The appointing authority at (i), (ii) and (iii) shall work under the superintendence and control of the Managing Director.

- (iv) Managing Director. Posts in Group D & C except post at i, ii, & iii above.
- (v) Personnel Committee. All other posts not covered at (i) to (iv).

B. Posts in Annexure C in the service of the Union.

- i) Chief Executive Posts in Group D in the Officer respective union.
- ii) Personnel Committee. All the posts not covered at (i) above.

14. General Conditions relating to appointments

14.1 The following general conditions shall apply to all appointments to the service.

No person shall be appointed to any posts in the service, unless he is :

- a) a citizen of India, or
- b) subject of Nepal or
- c) Subject of Bhutan or
- d) a Tibetan refugee who came over to India before 1st January, 1962 with the intention of permanent settling in India, or

- e) a person of Indian origin who has migrated from Pakistan, Burma, Sri Lanka, East African countries of Kenya, Uganda, The United Republic of Tenzania, Zambia, Maldiv, Zaira and Ethopia with the intention of permanently settling in India.

Provided that a person belonging to any of the categories (b), (c), (d) & (e) in whose favour a certificate of eligibility has not been issued by the Government may be admitted to an examination or interview but the offer of appointment may be given only after the necessary eligibility certificate has been issued to him by the Government.

14.2

No person shall be appointed to any post in the service unless he is in possession of qualification obtained from a University/Institute recognised by Govt. of India, and experience specified in Annexure B & D to these rules.

Provided that qualification prescribed for the direct recruitment shall also apply for appointment by transfer and appointments made on adhoc basis.

Provided further that in case of direct recruitment, the appointing authority may

relax the qualifications in favour of candidates belonging to Scheduled Castes/Tribes, Ex-servicemen, physically handicapped when candidates possessing requisite qualification are not available to fill up vacancies reserved for them.

14.3 No person shall be appointed by direct recruitment

- a) If he is less than 18 years old or above 45 years in age. (The upper age limit may be relaxed by the Appointing authority for posts requiring experience.)
- b) If he has previously been dismissed from the Services in Government department or Cooperative Institution or has been convicted by a court of law for an act involving moral turpitude.
- c) Unless he produced a certificate from the Principal Officer of the University, College, School or Institution last attended if any, and similar certificate from two other responsible persons, not being his relatives who are wellacquainted with him in his private life and are unconnected with the University, College, School or Institution.

- d) Unless his antecedents are verified by the Distt. Magistrate of the District where he has individually resided for more than three years during the last five years.
- e) - Unless he has been certified to be of sound physique and medically fit to discharge the duties by the Chief Medical Officer.
- f) If he has entered into or contracted a marriage with a person having a spouse living.
- g) If he is related to any of the Directors of the Federation or Union as the case may be.

15. Training :

15.1 The Managing Director of the Federation, in case of employees in Annexure A and the Chief Executive Officer of the Union, in case of employees in Annexure C, may depute any employee of the respective service to undergo any course of training connected with their business.

Provided that approval of the respective Board shall be obtained for deputing any employee for training outside the country subject to restrictions imposed by the Federation, Registrar or Government.

- 15.2 The employees deputed for training for a period of three months or above shall be required to execute a bond to serve the Federation or Union as the case may be for a period of three years after completion of training failing which he shall be required to refund the entire cost of training.
- 15.3 In case of Chief Executive Officer, Assistant Accounts Officer working with Union, the entire salary for the training period shall be paid by the Union concerned.
- Provided that the Federation shall reimburse salary beyond 30 days if any, to the concerned Union.
- 15.4 The appointing authority may require a class of employees to undergo a particular training or pass examination before he is confirmed or promoted or allowed to cross efficiency bar.
- 15.5 An employee who fails to complete the training successfully or pass the examination shall do the training again or take the examination as per rules of the training institution at his own expense .

- 15.6 The appointing authority may require the selected candidates to undergo a specific training before appointment to a post(s) and may allow a reasonable stipend for the above period of training which shall not exceed 50% of the salary of the post.

16. Security

- 16.1 The members of the service shall furnish such security and shall execute such bond in favour of the Federation or Union as the case may be, as is prescribed by the Appointing Authority.

17. Seniority

- 17.1 Separate interse seniority of each category of the service, as required in the channel of promotion provided in Annexure B & D, shall be determined by the length of continuous service on a post in that category. Length of service shall be reckoned from the date of issue of orders making appointment to the post.

Provided that in case of persons appointed by direct appointment, the order of merit determined by the Appointing authority shall not be disturbed in fixing the seniority.

Provided further that where merit on direct appointment is not determined by the appointing authority and length of conti-

in age shall be senior to the younger.

Provided further that the seniority of employees of Federation in Group D shall be fixed at the level of respective Milk Plant or Semen Bank cum-Training Centre, Rohtak or Model Exotic animal Farm, Bhiwani or Head Office of the Federation including Sales office as the case may be.

Provided further that in case of two or more persons appointed on the same day, their seniority shall be determined as below :-

- a) A person appointed by the direct recruitment shall be senior to a person appointed by promotion.
- b) In the case of person appointed by promotion, seniority shall be determined according to seniority of each person in the post from which they were promoted.
- c) In case two or more persons appointed by transfer on the same day, their seniority shall be determined according to the pay scale, preference being given to a member who was carrying a higher pay scale in his previous appointment and if the pay scales are also the same by the length of service in their earlier appointments and if the length of service is also the same, the

older member shall be senior to the younger.

17.2 Seniority of employees who are already in the service shall be determined according to Rule 17.1 above.

17.3 Persons appointed on deputation or on contract shall not be eligible for seniority in the service.

17.4 The Managing Director in case of Federation and the Chief Executive Officer in case of a Union shall be competent to screen and place the existing employees in the relevant category of posts provided that where the category/post does not exist, the employee may be placed on equivalent category.

18. Joint Seniority List of Certain Categories.

18.1 The Federation shall prepare Joint seniority list of following categories of posts in the service of the Federation and that of the Unions for the purpose of promotion as contained in annexure B to these rules.

a) Category 9 and 11 of the Annexure A & 4 of the Annexure C i.e. Assistant & Stenographers for promotion to the post of Assistant Personnel Officer (category 5 of Annexure A).

- b) Category 10 of annexure A and 5 of Annexure C i.e., Store-Keepers/Purchase Assistant for promotion to the post of Store Office (category 7 of annexure A).
- c) Category 26 (Accountant) of Annexure A and category 3 (Accountant) of Annexure C for promotion to the post of Senior Accountant (category 25), of Annexure A.
- d) Category 39 (Shift Manager) of Annexure A and Category 21 (Shift Manager) of Annexure C for promotion to the post of Deputy Manager (Production) category 37 of Annexure-A.
- e) Category 44 (Technical Assistant) & Category 45 (Bacteriologist) of Annexure A and Category 23 (Technical Assistant) of Annexure C for promotion to the post of quality Control Officer (category 40).
- f) Category 49 (Fitter, Jr. Mechanic, Compressor Operator of Annexure A, Category 25 (compressor operator) of Annexure C for promotion to the post of Mechanic (category 47) of Annexure A.
- g) Category 30 (Fodder Development Officer) of Annexure C for promotion to the post of

Agronomist (category 61 of Annexure A).

- h) Category 31 (MISO) of Annexure A and 12 (MISO) of Annexure C for promotion to the post of Senior MISO (Category 30) of Annexure A.
- i) Category 42 Dairy Supervisor of Annexure A and Dairy Supervisor 22 of Annexure C for promotion to the post of Shift Manager (39), of Annexure 'A'.
- j) Category 58 Artificial Insemination Officer of Annexure A & 14 Senior Milk Procurement Officer and 28 Artificial Insemination Officers of Annexure C for promotion to the post of Project Officer (category 55 of Annexure A).

18.2 The Joint seniority shall be fixed from the date of continuous service in the respective category. The above date shall be reckoned from the date of issue of order making appointment to the post. If the date of continuous service is the same, the older member shall be senior to younger.

19. Confirmation.

19.1 On having completed probation period successfully, an employee shall be eligible

for confirmation subject to availability of permanent post.

19.2 The confirmation shall be made on the basis of seniority determined under Rule 17, the senior to be confirmed first over junior. A specific date of confirmation shall be given to each employee.

19.3 No employee shall be deemed to have been confirmed in the service unless specific orders are issued in this regard by the appointing authority.

20. TRANSFERS.

20.1 A person in the service of the Federation or a Union shall be liable to serve in the State of Haryana or even outside the State where the Federation or Union operates or intends to operate its activities. A member of the service of the Federation or that of Union, may be deputed to serve other dairy cooperative^s in the country.

Provided that lending of service to other institutions shall atleast be on equivalent post and the period of deputation shall not exceed 5 years after which the employee shall revert back to his parent institution.

20.2 The Managing Director of the Federation in case of employees in the service of Federation and Chief Executive Officer in case of employees in the service of a union, shall be competent to make transfers.

Provided that employee of the Federation shall not be transferable to a Union(s) or an employee of a union shall not be transferable to the Federation or any other union except whose services are lent on deputation.

Provided further that the employees of the Federation in Group D shall not be transferable from their unit of allocation to the other.

Provided further that the Managing Director of the Federation shall be competent to post or transfer Chief Executive Officer and Assistant Accounts Officer of a Union.

20.3 The management may require an employee to hold an additional charge or officiate in two or more posts in addition to the post held by him.

CHAPTER - III21. PAY AND ALLOWANCES

21.1 An employee appointed to post in the service shall draw the pay of the post in the scale given in Annexure A & C of these rules or as revised by the Board of Directors of the Federation from time to time with the approval of Registrar.

22. Dearness Allowance and City Compensatory Allowance.

22.1 The dearness allowance or city compensatory allowance as applicable to employees of Government shall also be admissible to all employees in the service of the Federation or a union.

23. HOUSE RENT.

23.1 House rent allowance shall be allowed at the rates applicable to employees of Government.

24. MEDICAL ALLOWANCE.

24.1 Medical allowance or reimbursement of medical bills shall be allowed as per instructions issued from time to time by the Federation.

25. TRAVELLING ALLOWANCE.

25.1 Travelling allowance on transfer, tour and training etc. shall be the same as

applicable to the Government employees from
time to time.

26. PROVIDENT FUND.

26.1 Except the employees on deputation, from Government all employees shall be entitled to the benefit of contributory provident fund as per the provisions of the Employees Provident Fund Act, 1952.

27. BONUS.

27.1 All employees shall be allowed bonus as per provisions of Bonus Act as amended from time to time.

Provided that a Chief Executive Officer or Assistant Accounts Officer of a union or other employees working on deputation shall draw bonus on the scale admissible to employees of the union/Federation where he is working.

28. GRATUITY.

28.1 All employees shall be eligible for payment of gratuity as per provisions of payment of Gratuity Act, 1972.

29. OTHER ALLOWANCES.

29.1 Other allowance such as Rural Allowance, conveyance allowance to physically

handicapped and to other employees, overtime allowance to drivers and special pay to Steno-typists etc. shall be admissible to the concerned employees of the service on the same rates as are allowed to such employees under Government.

30. UNIFORM OR LIVERIES :

30.1 It shall be obligatory on each employee to wear uniform if so prescribed and such employees may be supplied summer and/or winter uniforms as per norms fixed by the Board of the Federation. The Federation or a Union as the case may be, may allow washing allowance to their employees, or a class of employees at such rate as is decided by the Board of Federation from time to time.

31. FINANCIAL LIABILITY.

31.1 Pay & allowances shall be paid to the Chief Executive Officer and Assistant Accounts Officer of a union, by the union where the duty is performed. Provided that the subsistence allowance for the period of suspension or salary on reinstatement in part or full for that period shall be paid by the Federation.

31.2 The pay and allowance in respect of Chief Executive Officer and Assistant Accounts Officer of a union for a period of leave other than casual leave shall

be paid by the Federation.

31.3 A Milk Union shall pay contribution towards leave salary, provident fund and gratuity etc. at the rate intimated to them by the Federation.

32. PAY FIXATION.

32.1 If an employee is promoted from a post of lower category to a post of higher category, his initial pay in the higher post shall be fixed at a stage in the new pay scale above the stage which works out in the pay scale of the lower post from which he is promoted after adding the amount of one increment to the pay he is actually drawing at the time of promotion.

33. ANNUAL INCREMENT.

33.1 Annual increment in the pay scale shall accrue automatically to an employee normally on the first day of the month in which he completes one year service unless it has been specifically withheld by order in writing passed by the punishing authority mentioned under Rule 48.5 of these Rules. Provided that the annual increment of an employee who is on leave (except casual leave) on the first day of the month shall actually be drawn from the date of resuming duty on return from leave.

33.2 The following periods shall count for completing the period of one year for the purpose of grant of

annual increment.

- a) Period of duty in the post.
- b) Period of leave with pay including half pay.
- c) Period of officiating service in higher post in the service provided the employee would have worked at the lower post but for his promotion to the higher post.
- d) Period of suspension if treated as duty by the appointing authority.
- e) Leave without pay upto 120 days taken on medical grounds.
- f) Period of study leave with or without pay.

34. EFFICIENCY BAR.

- 34.1 Increment at the stage of efficiency bar shall be considered and allowed by the appointing authority on the basis of annual confidential reports and in accordance with instructions issued by the Government in this behalf.

35. BIENNIAL INCREMENT.

- 35.1 Biennial increment shall be granted to eligible employees as per instructions applicable to Government employees.

CHAPTER - IVRESIGNATION, RETIREMENT AND TERMINATION36. TERMINATION NOT AS A DISCIPLINARY MEASURE.

36.1 The appointing authority may terminate the services of an employee appointed on adhoc basis, daily wages and apprentice without any notice and without assigning any reason.

Provided that concerned employee has not completed 240 days service over a period of 12 months from the date of first appointment.

36.2 The appointing authority may terminate an employee on probation, if his work and conduct during or on completion of probation has not been found satisfactory.

36.3 Where the posts are abolished by the Board of the Federation or union as the case may be, the affected employees shall be relieved of their job by giving them due notice or compensation in lieu of notice, or by reverting them to the posts from which they were promoted.

36.4 In case of retrenchment as contained in rule 36.3 above, the employee who was the last person to be employed in that category, shall be the first to be retrenched or reverted provided in case of employees appointed on adhoc basic, the first

person to be employed in that category shall be the first to be retrenched or reverted. The Federation or a union as the case may be may, however, request the Govt. to absorb the retrenched employees in Govt or other institutional jobs.

36.5 The services of an employee, appointed on contract for a specific period or for specific work shall stand terminated on the expiry of such period or on completion of such work and no notice shall be necessary in such cases.

36.6 No appeal shall lie against orders passed under this rule.

37. RESIGNATION

37.1 An employee may resign from the service of the Federation or Union as the case may be by giving one month notice or by depositing one month pay and allowances (basic pay and dearness allowance and special pay, if any) in lieu thereof.

37.2 Resignation shall be deemed to be operative only after it has been accepted by the competent authority.

37.3 The General Manager of a Milk Plant or Manager MEAF or Manager SBTC as the case may be where they are appointing authority and the Managing Director of the Federation in respect of other post(s) in

Annexure A and the Chief Executive Officer of a Union in respect of post in Annexure C shall be competent to accept the resignation.

37.4 The appointing authority may allow an employee to withdraw the resignation and may allow the ex-employee to join the services again as per instructions applicable to Government employees in this behalf.

38. RETIREMENT.

38.1 Every employee shall retire from the service on the afternoon of the last day of the month in which he attains the age of 58 years.

Provided that the age of retirement for employees in Group D service shall be 60 years.

Provided further that the employee where date of birth is the first of the month, shall retire on the afternoon of the last day of the preceding month, on attaining the age of 58 or 60 years, as the case may be.

39. RE-EMPLOYMENT.

39.1 No employee shall be retained in service after the age of retirement.

Provided that^a retired employee may be re-employed till he attains the age of 60 years by the Board of

Directors of the Federation/Union as the case may be in accordance with the condition laid down by the Government.

40. COMPULSORY RETIREMENT

40.1 The appointing authority shall have an absolute right to retire any employee by giving him notice of not less than three months in writing or three months pay and allowances in lieu of such notice.

Provided that he has completed 20 years of service or has attained the age of 50 years on the date of proposed compulsory retirement.

Provided further that the employees shall be deemed to have retired immediately on payment of three months pay and allowances in lieu of notice or on the expiry of the notice period and will not remain in the service thereafter.

41. VOLUNTARY RETIREMENT.

41.1 An employee may, by giving a notice of not less than three months in writing, to the appointing authority, retire from service.

Provided he has attained age of 50 years or has completed 20 years of service on the day of proposed retirement.

CHAPTER - V42. CASUAL LEAVE AND OTHER LEAVE.

42.1 Type of leave and authority competent to sanction.
Subject to provisions of these rules following kind of leave may be granted to an employee :-

(i) Casual leave (ii) Earned leave (iii) Half pay leave/commuted leave (iv) Extra ordinary leave (v) Maternity leave (vi) Study leave.

42.2 The authorities empowered to grant various kind of leave to the employee are given in Annexure E.

Such authorities shall also be competent to refuse leave or recall an employee at any time during his leave period without assinging any reason.

42.3 COMMENCEMENT AND TERMINATION OF LEAVE.

The first day of an employee's leave is the working day succeeding that on which he hands over charge and the last day is the working day preceding that on which he reports for duty. The employee before proceeding on leave shall intimate to the competent authority his leave address and shall inform the authority of any change in the address previously furnished. The employee shall return to duty to the place from which he proceeded on leave unless otherwise instructed.

42.4 CALCULATION OF VARIOUS KINDS OF LEAVE.

(a) CASUAL LEAVE.

(i) 10 days in a year for employees having service upto 10 years.

(ii) 15 days in a year for employees having service more than 10 years and upto 15 years.

(iii) 20 days in a year for employees having more than 15 years service.

(b) EARNED LEAVE.

(i) 1/24th of the period spent on duty during the first 10 years of service.

(ii) 1/18th of the period spent on duty during the next 10 years of service and

(iii) 1/12th of the period spent on duty thereafter.

(iv) Accumulation of earned leave shall be permissible to any extent but the maximum earned leave that may be granted at a time to an employee shall be 120 days.

(c) HALF PAY LEAVE.

(i) 20 days half pay leave will be admissible to an employee in respect of each completed year of service.

(ii) Half pay leave due may be granted to an employee on medical grounds, Half pay leave may be

commuted on medical certificate upto a maximum of 180 days and twice the amount of such leave shall be debited against the half pay leave due.

(iii) the total duration of earned leave and commuted leave taken in conjunction shall not exceed 240 days.

Provided that no commuted leave may be granted under this rule unless the authority to sanction believes that the employee will return to duty on its expiry.

(d) EXTRAORDINARY LEAVE :

Extraordinary leave may be granted to an employee in special circumstances :-

(i) When no other leave is admissible or

(ii) When other leave is admissible, but the employee concerned applies in writing for the grant of extra-ordinary leave.

(iii) The authority empowered to grant leave may commute retrospectively period of absence without leave upto extra-ordinary leave or extra-ordinary leave previously granted into a leave of different kind, if the latter type of leave was admissible at the time of extraordinary leave was granted.

(e) MATERNITY LEAVE.

The competent authority may grant maternity leave to a female employee for a period not exceeding three months from the date of its commencement. Leave salary at the rate of pay drawn immediately before proceeding on leave reduced by benefits drawn from the Employees State Insurance Corporation shall be paid during maternity leave and it shall not be debited against leave account.

(ii) any other kind of leave may be permitted to be pre-fixed to maternity leave without insisting on a medical certificate. But any leave applied for in continuation of the maternity leave may be granted only if the request is supported by a medical certificate.

(iii) The term pay includes officiating pay provided the authority sanctioning the leave certifies that the employee would have continued to officiate had he not proceeded on leave.

(iv) Maternity leave may also be granted in case of mis-carriages including abortion as per instructions applicable to Government employees and the application for leave is supported by a certificate from a registered Medical Practitioner. The certificate of a Chief Medical Officer, or Deputy Chief Medical Officer or Gazetted Medical

Officer may, however, be called for in case of doubt.

Maternity leave shall not be admissible to female employee having more than three living children. In such cases leave of the kind due or extraordinary leave will be allowed.

(f) STUDY LEAVE.

Leave may be granted in the interest of Federation/union to an employee on such terms as may be prescribed by general or special orders of the competent authority to enable him to study scientific, technical or similar problems or to undergo special courses of instructions. Such leave shall not be debited against the leave account. Orders issued by Government in dealing with such cases will be followed.

(f) ENCASHMENT OF EARNED LEAVE.

Encashment of earned leave upto 240 days shall be admissible if due at the time of retirement including voluntary and compulsory retirement or in case of death of an employee during service his heir can claim encashment of earned leave due subject to the limit of 240 days or as amended by Government from time to time

43. Leave as per Punjab Industrial Establishment National and Festival Holidays and Casual and Sick Leave, Act, 1965.

43.1 Notwithstanding anything contained in these rules, the Board of the Federation reserves the right to regulate National and Festival Holidays, casual or sick leave in accordance with the provisions of Punjab Industrial Establishment (National and Festival Holidays and Casual and sick leave) Act, 1965 and Rules made thereunder.

CHAPTER - VI

44. CONDUCT AND DISCIPLINE.

44.1 GENERAL.

Every employee shall at all times :-

- (a) Maintain absolute integrity.
- (b) Maintain devotion to duty.
- (c) do nothing which is unbecoming of an employee of the Federation.
- (d) abide by and comply with the regulations of the Federation and all orders and directions of the superiors.
- (e) discharge his duty to the best of his ability in the interest of the Federation.
- (f) no employee shall in the performance of his official duty in the exercise of the powers conferred on him, act otherwise than his best

judgement except when he is acting under the direction of his superiors.

44.2 (a) No employee shall be a member of or be otherwise associated with any political party or any organisation which takes part in political activities, subscribe in aid or, assist in any other manner any other political movement or activity.

(b) No employee shall take part or contest any election of a Panchayat Municipal Committee, State Legislative Assembly and Parliament but may exercise his right to vote, if any, at such election.

(c) No employee shall be elected office bearer of any cooperative society which is a member of a Union and or of Federation.

44.3 No employee shall join or continue to be member of association, the objects or activities of which are prejudicial to the interests of the sovereignty and integrity of India or public order of morality or to the interest of the Federation.

44.4 No employee shall engage himself or participate in any demonstration which is prejudicial to the interests of the sovereignty and integrity of India, the security of the State friendly relations

with foreign states, public order, decency or morality, or which involve contempt of court, defamation or excitement to an offence.

44.5

No employee shall in any radio broadcast or any document published in his own name or anonymously, pseudonymously or in the name of any other person or in any communication to the press or in any public utterance, make any statement of fact or opinion.

(a) which has the effect of any adverse criticism or any policy or action of the Federation/ Union.

(b) which is capable of embarrassing the relations between the Federation/Union/State Government, Central Government and the Government of any state or any foreign state.

(c) which is capable of embarrassing the relations between the Federation, Union and any other organisation.

Provided that nothing in this rule shall apply to any statement made or views expressed by an employee in his official capacity or in the due performance of the duties assigned to him.

44.6 (a) No employee shall except with the prior sanction of the management give evidence in connection with any inquiry conducted by any person committee or authority.

(b) Where any sanction has been accorded under sub-rule (i) no employee while giving such evidence shall criticise the policy or any action of the Federation/ Union.

(c) Nothing in this regulation shall apply to :-

i) Evidence given at any inquiry before an authority appointed by the Federation, Union, Government, Parliament or a State Legislature or

ii) Evidence given in any judicial inquiry;

iii) Evidence given at any departmental inquiry ordered by an officer empowered under these rules to order a departmental enquiry.

44.7 No employee shall, except in accordance with any general or special order of the Federation/union, in the performance of the duties assigned to him, communicate directly or indirectly the contents of any official document or any part thereof or other information to any other employee or any person to whom he is not authorised to communicate such contents or information.

44.8 No employee shall accept or permit any member of his family or any person acting on his behalf to accept.

(a) Any illegal gratification or

(b) Pecuniary advantage or gifts etc., from any person or agent having dealing with the Federation/Union except as prescribed by Government for Government employees.

44.9 No employee shall :-

(a) Give or take or abet the giving or taking of dowry or

(b) Demand, directly or indirectly, from the parents or guardian of a bride or bridegroom as the case may be, any dowry.

44.10 No employee shall engage himself directly or indirectly in any trade or business or undertake any other employment.

Provided that any employee may without such sanction undertake honourary work of a special or charitable nature or work of literary, artistic or scientific or cooperative or educational character, subject to the condition that his official duties do not thereby suffer.

Provided that an employee may take part in an honorary capacity in registration, promotion or

management of a cooperative society and which is required to be registered under the cooperative societies Act or any other laws for the time being in force, or of a literary, scientific or charitable society required to be registered under the Societies Registration Acts or any corresponding law in force.

- 44.11 (a) An employee shall so manage his private affairs to avoid habitual indebtedness or insolvency.
- (b) An employee against whom any legal proceedings are instituted for the recovery of any debt due from him or for adjudging him as an insolvent shall forthwith report the full facts of the legal proceedings to the Federation/Union.
- (c) The burden of proving that the insolvency or indebtedness was the result of circumstances which, with the exercise of ordinary deligency, the employee could not have foreseen or over which he had no control and had not proceeded from extravagant or dissipated habit, shall be upon the employee.
- (d) An employee shall not lend or borrow money as principal or agent to a firm or any person within the limits of his authority or with whom he is likely to have official dealings or otherwise place

himself under any pecuniary obligations to such persons.

Provided that an employee may give to or accept from a relative or a personal friend, a small amount free of interest or operate a credit account with a bonafide trader.

44.12 Any employee shall :

- (a) Strictly abide by the law relating to intoxicating drinks or drugs in force in the area in which he may happen to be for the time being take due care that the performance of his duties is not affected in any way by the influence of any intoxicating drink and drugs.
- (b) Not appear in a public place in a state of intoxication.
- (c) Not habitually use any intoxicating drink or drug.

44.13 (a) No employee shall, except with the prior sanction of the management, have recourse to any court or to the press for vindication of any official act which has been the subject matter of adverse criticism of an attack of a defamatory character.

- (b) Nothing in this rule shall be deemed to prohibit an employee from vindicting his private character or any act done by him in his private capacity and

where any action for vindicating his private character or any act done by him in private capacity is taken, the employee shall submit a report to the Managing Director/Chief Executive Officer regarding such action.

- (c) An employee shall not absent himself from his duties or from the station of his posting without having first obtained the permission of the competent authority.

45. MOVEABLE, IMMOVEABLE AND VALUABLE PROPERTY.

45.1 Every employee shall within a period of three months on his first appointment to any service or post and thereafter each year, submit a return of his assets and liabilities in form-I giving full particulars regarding :

- (a) The immovable property inherited by him or owned by him or held by him on lease or mortgage, either in his own name or in the name of any member of his family or in the name of any other person.
- (b) Shares debentures and cash including bank deposits inherited by him or similarly owned acquired or held by him.
- (c) Other moveable property such as loans and advances given, inherited by him or similarly owned, acquired or held by him.

(d) Debits and other liabilities incurred by him directly or indirectly.

45.2 No employee shall, except with the previous knowledge of the appointing authority, acquire or dispose off any immoveable property by lease, mortgage purchase, sell, gift or otherwise in his own name or in the name of any member of his family or any other name.

45.3 When an employee enters into a transaction in respect of moveable property either in his own name or in the name of a member of his family or any other name, he shall within one month from the date of transaction report the same to the appointing authority, if the value of such property exceeds two thousand rupees.

45.4 The appointing authority may at any time by general or special order require an employee to furnish within a period specified in the order, a full and complete statement of such moveable and immoveable property held or acquired by him on his behalf or by any member of his family as may be specified in the order.

Such statement shall if so, required include details of the sources by which or the source from which such property was acquired.

46. Minor Misconduct and its Penalties.

46.1 Misconduct such as minor negligence or neglect of work in which a fine may be imposed under the payment of Wages Act, 1936, ordinary absence late attendance, minor inefficiency, loitering, misuse of goods, not wearing uniforms during duty hours and any other misconduct unless otherwise stated as major misconduct shall constitute minor misconduct and the punishing authorities given in Rule 48.5 of these Rules may impose punishment such as :-

1st Offence	=	Warning in writing.
2nd Offence	=	Suspension without wages for not more than two days.
3rd Offence	=	Suspension without wages for not more than four days.

47. MAJOR MISCONDUCT.

47.1 All acts of misconduct and other acts of commission or omission specifically provided under these rules will be deemed to be major misconduct. Without prejudice to the general meaning of the term misconduct, it shall be deemed to mean and include the following (the list is only explanatory and not exhaustive) :-

- 47.1A Theft, fraud or dishonesty in connection with business or property of the Federation/Union.
- 47.2 Demanding, accepting or offering bribes or any illegal gratification whatsoever.
- 47.3 Smoking any where within the factory limits where it is prohibited by notice.
- 47.4 Drunkenness, fighting, threatening, riotous or disorderly or indecent behaviour within the factory/office premises and or while on duty or outside in connection with the affairs of the Federation/Union.
- 47.5 Sleeping on duty.
- 47.6 Wilful insubordination or disobedience whether alone or in combination with others, to any lawful and reasonable order of a superior.
- 47.7 Anywhere within the limits of the factory/office committing or inciting others to commit breaching of law or rules of the Federation/Union or the commission of any other act intended to harm the interests of the Federation/Union or the commission of any other act intended to harm the interests of the Federation/Union or its employees.
- 47.8 Mis-statement made on application for employment.

- 47.9 The collection of money or distribution of propaganda leaflets or pasting of notices in the factory office without the permission in writing of the Management.
- 47.10 Committing any act likely to harm or endanger the plant or property or likely to interfere with his own production and/or earning capacity or that of any other employee(s).
- 47.11 Engaging in or inciting others to engage in strike or go slow tactics of trade union activities within the factory/office premises.
- 47.12 Conviction for any offence involving moral turpitude.
- 47.13 Refusal to offer himself for interrogation by the personnel Department/Management.
- 47.14 Refusal to accept any communication or charge sheet from the Management.
- 47.15 Habitual negligence or neglect of work.
- 47.16 Habitual indiscipline or loitering.
- 47.17 - Refusal to work or accept any alternative work if such alternative employment does not call for any special skill or previous experience and can be done by the employee.

Provided that the wages which would have normally been paid to the employee are not adversely affected for the alternative job.

- 47.18 Gambling within the factory office premises.
- 47.19 Lending or borrowing money from subordinate employee.
- 47.20 Writing of anonymous letter levelling frivolous charges against any official/officer of the Federation/Union.
- 47.21 Theft of employee's property inside the factory/office.
- 47.22 Leaving factory/office without permission during working hours.
- 47.23 Holding any meeting in the factory/office or taking any part in the same without permission of the Management.
- 47.24 Calling upon persuading or inviting an employee or essential or confidential service to stop work or go on strike.
- 47.25 Acting in any manner against an agreement or award under Industrial Disputes Act, 1947 during the currency of the agreement/award.

- 47.26 Abetment/and/or attempt to commit any of the acts of major misconducts.
- 47.27 Habitual breach of rules or instructions for the maintenance and running of any department, machine or the maintenance of the cleanliness of any portion of the establishment.
- 47.28 Unauthorised entry into or stay in the factory/office by employee while on strike.
- 47.29 Failure to observe safety instructions or interference with any safety device or equipment installed within the establishment.
- 47.30 Doing private or personal work within the factory/office during working hours without prior permission of the management.
- 47.31 Wilful falsification, defacement or destruction of personal records of the factory/office.
- 47.32 Unauthorised possession of any lethal weapon in the factory/office.
- 47.33 Refusal to sign the statement made before any officer of the Federation/Union.
- 47.34 Taking part or participation in a strike which is illegal or is in contravention of any law.
- 47.35 To take part or to go on strike by employees employed in essential, confidential and emergency

department.

47.36 To obtain leave by mentioning false reasons.

47.37 Habitual late attendance or habitual absence without leave or remaining absent for more than 3 days at a time without proper permission.

47.38 Wilful damage to machinery or waste of materials or stores as also loan of goods or property of the factory.

47.39 Disclosing to an unauthorised person any information with regard to the establishment which may come into the possession of the employee in the course of his work.

47.40 Indulging in scurrilous attacks against the management and other superiors of the employee in his official capacity.

47.41 Slowing down of work and failure to achieve targets.

47.42 Accumulation of money or property disproportionate to the known sources of income.

48. PENALTIES.

48.1 Notwithstanding anything contained in any other regulation and without prejudice to such action to which an employee becomes liable under any other

law or regulation for the time being in force, the following penalties may be imposed for good and sufficient reasons on any member of the service.

MINOR PENALTIES :

- (a) Censure.
- (b) Warning with a copy on ACR.
- (c) Withholding of increment with or without cumulative effect.
- (d) Recovery from pay or such other amount as may be due of the whole or part of pecuniary loss caused to Federation/Union/Societies by negligence or breach of orders.
- (e) Withholding of promotion for a specified period.

MAJOR PENALTIES.

- (f) Reduction to a lower category.
- (g) Removal from service.
- (h) Dismissal from service.

48.2 The following shall not constitute a penalty within the meaning of this rule :-

- (a) Termination of service or reversion to lower service grade or post of an employee appointed or promoted on probation either during or at the end of the probation initial or extended as the case may be.

(b) Termination of service in accordance with the terms of appointment of an employee, when the employee is appointed on adhoc-basis or daily wages and has not completed 240 days service over a period of 12 months from the date of first appointment.

(c) Discharge of employee for want of vacancy or as a measure of retrenchment.

(d) Reversion of an employee promoted from a lower post to a higher post, to such lower post for want of vacancy.

(e) Suspension.

48.3 (a) No disciplinary action shall be initiated against an employee unless the charge(s) on which it is proposed to take disciplinary action against him have been communicated in writing and he has been given a reasonable opportunity of showing cause against the action proposed to be taken against him.

(b) If the authority competent to impose penalty, after consideration of the reply to the charge sheet, is of the opinion that any of the penalties specified at (a) to (e) of para 48.1 above should be imposed on the employee, it shall not be necessary to hold further enquiry or to give the employee any opportunity of making representation on the penalty proposed to be imposed.

(c) In other cases the competent authority may hold an enquiry into the charge(s) or cause such an enquiry to be held by an officer superior in rank to the person against whom the action is proposed to be taken with the purpose of ascertaining the truth or otherwise of the charges. In that event the employee concerned shall be permitted to cross-examine witness deposing against him and also to adduce evidence in defence and examine the relevant documents but shall not be permitted to engage a lawyer during the enquiry.

(d) On receipt of the enquiry report the competent authority shall apply its mind and come to the conclusions regarding the punishment to be awarded. In case the authority do not agree with the findings of the Enquiry Officer it will record a note of dissent giving detailed reasons for disagreement.

(e) The competent authority shall pass speaking order with regard to the punishment to be awarded and shall communicate the same at the last known address.

48.4 Notwithstanding anything contained in these rules, the services of an employee who ^{is} convicted by competent court for an offence involving moral turpitude shall be terminated forthwith by the

competent authority.

48.5 The authority specified in column (4) below shall in respect of an employee of the description specified in column (2) thereof be competent to impose penalties mentioned in Column (3).

The appellate authority shall be as given in coloum 5 in each case.

Sr.No.	Description of Employee	Nature of Penalties	Authority competent to impose penalty.	Appellate Authority
1.	2.	3.	4.	5.

Employees in Annexure-A

i)	Employees in Group D	All Penalties under Rule 48.1		
	a) Milk Plant		General Manager Milk Plant	Managing Director
	b) Semen Bank-cum-Training Centre	-do-	Manager SBTC	-do-
	c) Model Exotic Animal Farm, Bhiwani	-do-	Manager MEAF	-do-
ii)	Employees in Group D & C except Sr.No. (i) above.	-do-	Managing Director	Personnel Committee
iii)	Employees in Group B & A	Minor Penalties (a) to (e) of Rule 48.1	Managing Director	Board
iv)	Employees in Group B & A	Major Penalties (f) to (h) of Rule 48.1	Personnel Committee	Board

Employees in Annexure-C

v)	Employees in Group D in the respective union	All Penalties under Rule 48.1	Chief Executive Officer	Personnel Committee
vi)	Employees in Group C in the respective union	Minor Penalties (a) to (e) of Rule 48.1	-do-	-do-
vii)	-do-	Major Penalties (f) to (h) of Rule 48.1	Personnel Committee	Board
vii)	Employees in Group B & A in the respective union	All Penalties in Rule 48.1	Personnel Committee	Board

49. SUSPENSION :

49. (a) Where disciplinary proceedings against an employee are contemplated or are pending or where criminal proceedings against him in respect of any offence are under investigation, or are under trial and the punishing authority as per Rule No.48.5 is satisfied that ^{it} is necessary or desirable to place the employee under suspension, he may, by an order in writing suspend him with effect from such date as may be specified in the order. Provided that Managing Director of the Federation in respect of employees in the services of Federation and the Chief Executive Officer in respect of employees in the service of the Union shall also be competent to place any employees under suspension.

(b) An employee under suspension shall be entitled to a subsistence allowance equal to 50% of his salary.

Provided that when ^{the} period of suspension exceeds six months the authority making the suspension order shall be competent to vary the amount of subsistence allowance for any period subsequent to the period of first six months as follows :-

(i) the amount of subsistence allowance may be

increased by 50% of the subsistence allowance admissible during first six months if the suspension has been prolonged for reasons to be recorded in writing not directly attributable to the employee.

- (ii) The amount of subsistence allowance may be reduced by an amount not exceeding 50% of the subsistence allowance admissible during first six months if the period of suspension has been prolonged due to the reasons, to be recorded, in writing, directly attributable to the employee.
- (c) In addition to the amount mentioned in (b) above the employee shall be entitled to any other compensatory allowance admissible on the basic of pay of which the employee was in receipt on the date of suspension subject to the fulfilment of other conditions laid down for the drawal of such allowance.
- (d) An employee under suspension may be reinstated by an authority competent to punish under Rule 48.5 of these Rules who shall consider and make specific orders with regard to the pay and allowance to be paid for the period of suspension and whether or not the said period shall be treated as duty.

Provided that where the said authority is of the opinion that the employee has been fully exonerated or that the suspension was wholly unjustified the employee shall be given the full pay and allowances to which he would have been entitled had he not been suspended and the period shall be treated as duty for all purposes.

In other cases the employee shall be given such proportion of pay and allowances as the punishing authority may prescribe keeping in view the extent to which the employee has been found guilty. In such cases, the period of suspension shall not be treated as duty unless such punishing authority specifically directs that it shall not be so treated for any specified purpose.

Provided further that such proportion of such pay and allowances shall not be less than the subsistence allowance admissible under clause (b) and (c) above.

- (e) The payment of subsistence allowance is subject to the furnishing of a certificate by the - employee to the satisfaction of the authority which suspended him that he is not engaged in any other employment, business, profession or vocation.

50. Charge sheet and appointment of enquiry officer

50.1 The Managing Director/Chief Executive Officer except in case of 48.5 (i) above shall be competent in all cases to issue charge-sheet, obtain explanation and appoint an Enquiry Officer. The final punishment shall, however, be imposed by the punishing authority mentioned in Rule 48.5 above.

51. APPEAL :

51.1 Appeal against the orders of punishment shall lie to authority mentioned in column 5 of Rule 48.5 of these rules.

51.2 The appeal shall be submitted within a period of 30 days from the date on which the applicant received a copy of the order appealed against. The appellate authority may, however, entertain any appeal within 60 days of the said date if the applicant had sufficient cause for not submitting the appeal in time.

51.3 Every appeal shall be submitted through the punishing authority or Chief Executive Officer, or Managing Director as the case may be who shall place the same before the appellate authority.

51.4 The appellate authority may, after consideration of the case :-

(i) Set aside, reduce, confirm or enhance the penalty.

OR

(ii) Remand the case to the authority which imposed penalty with such directions as it may deem fit in the case.

Provided that before enhancement of the Penalty the appellate authority will give notice to the appellant to show cause against the proposed enhancement.

52. Revision.

52.1 No revision petition against the decision of the appellate authority shall lie to anybody.

CHAPTER-VII.

GENERAL

53. RECORD OF SERVICE.

53.1 The record of service of every employee inclusive of accounts of all types of leave (except casual leave) pay scales, annual increments, crossing efficiency bar, biennial increments, dates of joining the services on transfer, promotion, confirmation and punishment if any, shall be

maintained or caused to be maintained by the Managing Director of the Federation in case of posts given in Annexure 'A' and by Chief Executive Officer in case of post(s) given in Annexure 'C', in the service books as applicable to Government employees. All entries in the service book shall be confirmed by an officer appointed by the above said officers. The employees shall have a right to see their service books.

54. ANNUAL CONFIDENTIAL REPORTS :

54.1 Character Roll of each employee shall be written each year in the month of April or immediately thereafter or whenever a special entry is required to be made in respect of good work or serious lapse of the employee.

Provided that the Reporting Officer Reviewing Officer and accepting Officer shall record his remarks only if the employee has worked for a minimum period of three months over a year under his supervision.

54.2 The character roll of employees in Group A, Group B, Group C and Group D of the service shall be written on a proforma F(1), F(2), F(3) and F(4) in respect of Group A, Group B and C and Group D employees respectively annexed to these rules and shall be finalised by the end of June each

year. The various officers authorised to make first report, to review and to accept the ACR are given in Annexure 'G'.

54.3 The reporting officer shall in the beginning of the year set physical and financial targets in consultation with each of the officers with respect to whom he is required to report upon. The targets shall be set for the commencement of the reporting year i.e. April.

In case of an officer taking up a new assignment in the course of the reporting year, such targets shall be set at the time of assumption of new assignment. The targets so fixed should be clearly known and understood by both the officers concerned. Priority shall be assigned item-wise taking into consideration the nature and area of work and any special features specific to the officer to be reported upon.

54.4 The reporting officer and the officer reported upon shall meet during the course of the year at regular intervals to review the performance and to take necessary corrective steps.

The assignment shall be confined to the performance during the period of report only.

54.5 In case adverse remarks are recorded in respect of an employee, the same shall be communicated to the employee within a period of two months from the date of its acceptance.

54.6 An appeal against the adverse remarks may be made within 30 days from the date of despatch of information containing adverse remarks. The appeal shall be considered by the officer given in column 6 of annexure H for decision whose decision shall be final and binding.

60 days as per amendment carried out vide B.O. 2 resolution no. 1785 dt 30-4-00.

55. Joining Time on transfer

55.1 Joining time upto 6 days shall ordinarily be admissible to an employee unless the authority competent to transfer, reduces it in the transfer orders. The employee shall, however, be eligible to avail reduced joining time on a later date within 6 months from the date of taking over the charge.

55.2 Public holidays following the day of his relieving shall not be included in the joining time.

55.3 Journey day of one day for each journey of 300 Km or its part, shall also be admissible on transfer.

55.4 No joining time & journey time shall be admissible when there is no change of station.

55.5 Joining time upto the number of days spent on travelling shall be admissible if the transfer is made on the request of the employee.

56. Military Service Benefit

56.1 Benefit of military service to the ex-servicemen employees joining service will be allowed as per rules applicable to Government employees.

57. Promotion of Small Family Norms

57.1 The employees shall be eligible to the special increments and other benefits for promoting small family norms in accordance with the instructions issued by Government from time to time.

58. Death during Service

58.1 Ex-gratia grant, employment and other concessions to the dependants of the employees shall be allowed in accordance with the instructions applicable to Government employees.

59. Conveyance Allowance.

59.1 Conveyance allowance to blind and orthopaedically handicapped employees shall be allowed in accordance with the instructions applicable to Government employees.

60. Loan to staff members.

60.1 Conveyance, house building, marriage loan or other loan may be granted to an employee as per

Government Rules and as per scheme approved by Registrar under Section 64 of the Haryana Cooperative Societies Act. 1984.

61. Standing orders.

61.1 Employees of the Federation/Union working in Milk Plants and other field units of the Federation/Unions, covered under Certified Standing orders issued under Section 50 of the Industrial Employment (Standing Orders) Act 1946, as amended from time to time, shall continue to be governed under the above said standing orders.

Provided that the provisions of these Rules shall only be applicable on such terms & conditions of service where the above standing Orders are silent.

62. Leave Travel Concession

62.1 Leave Travel Concession shall be admissible to employees as per instructions applicable to Government employees.

63. Amendment of Rules

63.1 The Federation may of its own motion or on the request of a union consider, to make amendment (including addition & deletion) in these rules and may for this purpose approve a model amendment of these Rules.

63.2 The model amendment as approved under Rule 63.1 shall be circulated to all concerned unions for consideration and approval by their respective Boards.

63.3 The Board of the Federation may, if it is satisfied that it is essential & desirable in the interest of the unions & Federation to carry the amendment, it may approve the amendment to be given effect from the date to be specified by it, provided at least 2/3rd of the unions have already approved the proposed amendments and due consideration was given to the views of the unions opposing the proposed amendment if any.

64. Relaxation.

64.1 Where the concerned Board of Directors is of the opinion that it is necessary or expedient so to do, he may by order for reasons to be recorded in writing, relax any of the provisions of these Rules with respect to any class or category of employees.

65. Interpretation of Rules.

65.1 If any doubt arises at any time, as to the interpretation of these rules or their application notwithstanding anything contained in these rules, the matter will be referred to Registrar whose decision shall be final.

66. Saving.

66.1 Where these rules are silent, the provisions of Civil Services Rules and instructions of Government Applicable to Government employees shall apply to the employees covered by these rules.

67. Repeal.

67.1 Various instructions, resolutions of Board of Directors of Federation and Unions governing the service conditions of employees, issued from time to time are hereby repealed in so far as they are repugnant to these rules.

HARYANA DAIRY COOPERATIVE'S STAFF SERVICE RULES, 1988

ANNEXURE-A

(Referred to in Rule 3.1)

Categories of posts in the service of Haryana Dairy
Development Cooperative Federation Limited

Sr.No.	Category of Post	Pay Scale
1	2	3
	<u>A. GENERAL</u>	
1.	Managing Director	5900-6700
	<u>B. ADMINISTRATION</u>	
2.	Chief Administrative Officer	3700-5000
3.	Manager, Personnel & Administration	2200-4000
4.	Purchase Officer	2000-3500
5.	Assistant Personnel Officer	2000-3200
6.	Labour Welfare Officer	- do -
7.	Store Officer	- do -
8.	Personal Assistant (Chairman/MD)	1640-2900
9.	Assistant	1400-2600
10.	Store-keeper (Purchase Assistant)	- do -
11.	Stenographer	- do -
12.	Security Officer	- do -
13.	Driver	1200-2040 + Special pay of Rs. 200/- at Head Office & Rs. 100/- in the field for car-jeep drivers only.
14.	{ Store Clerk/ Junior Store Keeper/ Store Care Taker/	950-1500
15.	Clerk ¹ Purchase Clerk.	- do -

16.	Steno-Typist	- do - +	Special pay as per Government Rules.
17.	Guest House Keeper/Cook	- do -	
18.	Jamadar/Daftri/Machine Operator	800-1150	
19.	Security Havildar	775-1025	
20.	Peon/Sweeper/Watchman/ Gardner/Labourers/Gateman/ Van Attendant/Lab.Attendant/ Bull Attendant Sewerman/Helper.	750-940 +	Special allowance to Sweeper as per Govt. Instructions.

C. ACCOUNT & FINANCE

21.	Manager (Accounts & Finance)	3000-4500	
22.	Deputy Manager, Accounts	2200-4000	
23.	Accounts Executive	2000-3500	
24.	i) Assistant Accounts Officer	2000-3200	
	ii) Audit Officer	- do -	
25.	Senior Accountant	1640-2900	
26.	Accountant	1400-2600	
27.	Accounts Clerk	1200-2040	

D. PLANNING & MONITORING

28.	Manager, Planning & Monitoring	3000-4500	
29.	Deputy Manager, Planning & Monitoring	2200-4000	- ① Sybil Angeel
30.	Senior Management Information System Officer	2000-3200	
31.	Management Information System Officer	1640-2900	—

E. PRODUCTION & PROJECTS

32.	Director Production & Projects	3700-5000	✓
33.	General Manager, Projects	3000-5000	✓ — [Manjari Das Munish Sya 122

34.	General Manager, Milk Plant	- do -	{ 900.
35.	Manager, Production	3000-4500	— 2
36.	Dairy Engineer	- do -	
37.	Deputy Manager, Production	2200-4000	— 2
38.	Deputy Manager, Quality Control	- do -	— 2
39.	Shift Manager	2000-3500	—
40.	Quality Control Officer	- do -	2
41.	Junior Dairy Engineer	- do -	
42.	Dairy Supervisor	1640-2900	
43.	Foreman	- do -	
44.	Technical Assistant	- do -	
45.	Bacteriologist	- do -	
46.	Senior Boiler Attendant	1400-2600	
47.	Mechanic/IN2 Plant Operator	- do -	
48.	Assistant Dairy Supervisor	- do -	
49.	Fitter/Compressor Operator/ Junior Mechanic	950-1500	
50.	Boiler Attendant	- do -	
51.	Laboratory Assistant	- do -	
52.	Plant Operator (Dairy)	- do -	
53.	Welder	750-940	
54.	Dairyman	- do -	

F. PROCUREMENT & INPUT

55.	X Project Officer X X	3000-5000	X — 1/2 handle meat
56.	Manager (SBTC)	3000-4500	
57.	Manager (MEAF)	3000-4500	
58.	Artificial Insemination Officer	2200-4000	

59.	Veterinary Officer	2000-3500
60.	Milk Procurement Officer	- do -
61.	Agronomist	- do -
62.	Assistant Fodder Development Officer	1640-2900
63.	Field Assistant (MEAF)	1400-2600
64.	Livestock Assistant (MEAF)	- do -

G. COOPERATION

Am sanctioned

65.	Institutional Development Officer	3000-5000 — ?
65. A.	Deputy Registrar Cooperative Societies.	2200-4000
66.	Inspector, Cooperative Societies	1400-2600

H. MARKETING

67.	Director Marketing	3700-5000	= single case.
68.	Manager Sales	2000-3500	
69.	Sales Officer	1640-2900	
70.	Sales Representative	1400-2600	
71.	Commercial Artist	- do -	3 yrs
72.	Salesman/Sales Girl/ Sales Clerk	950-1500	

I. CIVIL ENGINEERING

73.	Executive Engineer	3000-4500
74.	Sub-Divisional Officer (Civil)	2000-3500
75.	Junior Engineer (Civil)	1400-2300
76.	Draftsman (Civil)	- do -
77.	Plumber	950-1500
78.	Carpenter	800-1150

79. Mason

- do -

PAY SCALES

1.	5900-6700	=	5900-200-6700
2.	3700-5000	=	3700-125-4700-150-5000
3.	3000-5000	=	3000-100-3500-125-5000
4.	3000-4500	=	3000-100-3500-125-4500
5.	2200-4000	=	2200-75-2800-EB-100-4000
6.	2000-3500	=	2000-60-2300-EB-75-3200-100-3500
7.	2000-3200	=	2000-60-2300-EB-75-3200
8.	1640-2900	=	1640-60-2600-EB-75-2900
9.	1400-2600	=	1400-40-1600-50-2300-EB-60-2600
10.	1400-2300	=	1400-40-1800 ^{EB} -50-2300
11.	1200-2040	=	1200-30-1560-EB-40-2040
12.	950-1500	=	950-20-1150-EB-25-1500
13.	800-1150	=	800-15-1010-EB-20-1150
14.	775-1025	=	775-12-870-EB-14-1025
15.	750-940	=	750-12-870-EB-14-940

HARYANA DAIRY COOPERATIVE'S STAFF SERVICE RULES, 1988

ANNEXURE-B

(Refer to in Rule 4)

Qualification and nature of recruitment in the Federation

(A) GENERAL

1. Managing Director

To be appointed by Government as per provisions of Haryana Cooperative Societies Act, 1984. Where no such appointment is made by Govt. direct appointment to be made by Personnel Committee as per following qualifications.

Direct = 100%

Degree in Dairy Technology/Food Technology/Engineering/Animal Husbandry, Marks 60% or above with MBA or Post Graduate Diploma in Management equivalent to MBA.

or

Chartered Accountant Marks 60% or above.

or

M.Com. or M.A. Economics with Master of Business Administration or Post Graduation Diploma in management equivalent to MBA.

15 years experience out of above 10 years in a Senior Managerial Position in processing unit of repute.

(B)

2. Chief Administrative Officer

Promotion = Nil
ADMINISTRATIO-N

Direct = 100%

Law Graduate with MBA or Post Graduate Diploma equivalent to MBA.

12 years experience of dealing matters relating to Establishment & Labour Laws in an organisation of repute.

3. Manager Personnel-&
Administration

Promotion = Nil

Direct = Nil.
Promotion = 100%

Out of category 5 & 6 with minimum experience of 7 years as Assistant Personnel Officer or Labour Welfare Officer. Must at-least be Graduate with Diploma in Personnel Management and Industrial Relations or Law Graduate.

4. Purchase Officer

Direct = 50%

MBA with specialisation in Store and Material Management (Marks 50% or above).

or

Graduate with Diploma in Material Management.

or

Diploma in Store and Inventory Control 3 years experience in Inventory Control and Material Management.

Promotion = 50%

Out of category 7 having 3 years experience as Store Officer, must at-least be Graduate.

5. Assistant Personnel Officer

Direct = 50%

Graduate - Marks 55% having 5 years experience of dealing in Establishment matters. Law Graduate/Diploma in Personnel Management shall be preferred.

Promotion = 50%

Out of category 9 & 11 of Annexure A and category 4 of Annexure C with 7 years experience as Assistant or Stenographer. Must atleast be Graduate.

6. Labour Welfare Officer

Direct = 100%

Graduate in Economics or Commerce or Sociology (Marks 50% or above) with Diploma in Social Welfare or Diploma in Industrial Relations and Personnel Management. 3 years experience of dealing in labour laws/problems in an organisation of repute. law graduate with specialisation in labour laws will be preferred.

Promotion = Nil.

7. Store Officer

Direct = Nil
Promotion = 100%

Out of category 10 of Annexure A and 5 of Annexure C and having 7 years experience as Store Keeper or Purchase Assistant. Must atleast be Graduate.

8. Personnel Assistant
(Chairman/MD)

Direct = Nil
Promotion = 100%

Out of category 11 having 7 years experience as Stenographer. Must atleast be a Graduate. A promotee shall have the option of keeping lien as Stenographer for promotion to the post of Assistant Personnel Officer.

9. Assistant

Direct = Nil
Promotion = 100%

Out of category 15 having 7 years experience as Clerk.

10. Store-Keeper (Purchase Assistant)

Direct = 50%
Graduate with Diploma in Material Management or Diploma in Store and Inventory Control.

Promotion = 50%

Out of category 14, 7 years experience as Junior Store Keeper etc. Must atleast be Matriculate.

11. Stenographer

Direct = Nil
Promotion = 100%

Out of category 16 with 7 years experience as Steno-typist. Minimum

speed in English & Hindi in shorthand 100 w.p.m. & 80 w.p.m. and typing speed 40 w.p.m. & 30 w.p.m. respectively on test.

12. Security Officer

Direct = 100%

Ex-serviceman Commissioned Officer

or

Junior Commissioned Officer, with minimum 15 years experience of service in Army, Must atleast be a matriculate.

Promotion = Nil.

13. Driver

Direct = 100%

Middle with driving licence of heavy and light vehicle, at least 3 years experience of driving a vehicle. Preference will be given to employees of the Federation possessing valid driving licence.

Promotion = Nil

14. Junior Store Keeper/
Store Clerk/Store Care
Taker/Purchase Clerk

Direct 100%
Matric 60% or above
or Graduate.

Promotion = Nil

15. Clerk

Direct = 75%

Matric 60% or above or Graduate
Typing speed English 35 w.p.m. or
Hindi 25 w.p.m.

Promotion = 25%

Out of category 18 and 20, with 7 years experience after attaining matriculation as Jamadar-Daftri, Machihe operator, Peon, Sweeper, Watchman Gardner, laourer, Gateman, Lab. Attendant, Bull Attendant, Sewerman, Helper etc.

16. Steno-typist

Direct = 100%

Graduate with minimum typing speed in English of 35 words per minute

- and shorthand speed 80 w.p.m. & typing speed in Hindi 30 w.p.m. and shorthand 64 w.p.m. respectively.
Promotion = Nil.
Direct = 100%
Middle pass having experience in cooking.

Promotion = Nil.
17. Guest House Keeper/
Cook
18. Jamadar-Daftri-Machine
Operator
19. Security Havildar.
20. Peon, Sweeper, Watchman,
Gardner, Labourer, Gate-
man, Van Attendant, Lab.
Attendant, Bull Attendant
Helper, Store Attendant
- (C) ACCOUNT & FINANCE
21. Manager (Account & Finance) Direct = 100%

Chartered Accountant/Institute of
cost & works Accountant with 4
years post qualification experience
in accounts & financial management.

or

Chartered Accountant(Inter)/Institute of
Cost and Works Accountants (Inter)/
with 8 years experience in accounts
and finance management.

Promotion = Nil
22. Deputy Manager Accounts
23. Accounts Executive
- Direct = Nil
Promotion = 100%

Out of category 23 having 7 years
experience as Accounts Executive.
Must atleast be a Graduate in
commerce or State Accounts Service
(Commercial).

Direct = Nil

24. Assistant Accounts
Officer/Audit Officer

Promotion = 100%

Out of category 24 having 3 years experience as Assistant Accounts Officer-Audit Officer.

Direct = 50%

Chartered Accountant (Inter)
Institute of Cost & Works Accountant
(Inter).

or

M.Com. (55% marks) with 3 years post qualification experience in maintenance of accounts. B.Com. (60% marks) with 5 years post qualification experience in maintenance of accounts.

Promotion = 50%

Out of category 25, having 7 years experience as Senior Accountant. Must at least be Graduate in Commerce.

25. Senior Accountant

Direct = Nil

Promotion = 100%

Out of category 26 of Annexure-A and category 3 of Annexure-C, having 7 years experience as Accountant. Must at least be Graduate in commerce.

26. Accountant

Direct = 50%

B.Com. (Marks 55% or above) with 3 years post qualification experience in maintenance of accounts.

or

M.Commerce(Marks 55%) or above with one year post qualification experience in maintenance of accounts.

Promotion = 50%

Out of category 27 with 7 years experience as Accounts Clerk.

27. Accounts Clerk

Direct = 100%

B.Com. (Marks 50% or above)
 B.A./B.Sc. for employees of
 Federation with 5 years experience
 in Accounts.

Promotion = Nil.

(D) PLANNING AND MONITORING

28. Manager (Planning &
 Monitoring)

Direct = 100%
 Chartered Accountants/Institute of
 cost & works Accountant with 4 years
 post qualification experience in
 planning and Monitoring

or

Chartered Accountant (Inter)/Insti-
 tute of costs & works Accountants
 (Inter) with 8 years experience in
 Planning & Monitoring.

or

Post Graduate Diploma equivalent to
 MBA or MBA with 8 years experience
 in planning & Monitoring.

or

B.Sc. dairying, M.A. Economics/
 Statistics Marks 60% or above with
 8 years experience in Planning &
 Monitoring.

Promotion = Nil

29. Deputy Manager
 (Planning & Monitoring)

Direct = Nil
 Promotion = 100%

Out of category 30 having 7 years
 experience as Senior Management
 Information System Officer. Must
 atleast be M.Sc. Dairy Economics or
 Post Graduate Diploma in management
 equivalent to M.B.A. or M.A.
 Mathematics or M.A. Statistics or
 M.A. Economics or B.Sc. Dairying.

30. Senior Management
 Information System
 Officer.

Direct = Nil.
 Promotion = 100%
 Out of category 31 of Annexure A
 and 12 of Annexure C having 7 years
 experience as Management Information
 System Officer. Must atleast be

M.Sc. in Dairy Economics or Post Graduate Diploma in Management equivalent to M.B.A. or M.A. Economics, Mathematics/Statistics/or B.Sc. Dairying.

31. Management Information System Officer.

Direct = 100%
M.Sc. Dairy Economics or M.A. Mathematics/Statistics/Economics or MBA/Post Graduate Diploma in Management equivalent to MBA with specialisation in MIS.

or

B.Sc. Dairying with one year experience in MIS work.

Promotion = Nil.

E. PRODUCTION AND PROJECTS

32. Director (Production & Projects)

Direct = 100%
B.Sc. Dairying or B.E. Mechanical marks 60% or above with 15 years experience in the line out of which 5 years should be as Head of a Milk Plant.

or

M.Sc. Dairy Engineering. 10 years experience in the line out of which 5 years as Head of a Milk Plant.

Promotion = Nil.

33. General Manager (Projects)

Direct = 100%
B.E. (Mechanical), marks 60%, or above 10 years experience in the line out of which 2 years should be in a Dairy Plant and two years in Project Planning and implementation work or M.Sc. Dairy Engineering marks 60% or above. 7 years experience in the line of which 2 years in a Dairy Plant or 2 years in Project Planning and implementation work.

Promotion = Nil.

34. General Manager Milk Plants

Direct = 50
B.Sc. Dairy Technology marks 60% or above, with 10 years experience in a

senior position in a Dairy Plant of an organisation of repute.

or

M.Sc. Dairy Technology, marks 60% or above. 5 years experience in a senior position in a Dairy Plant of an organisation of repute.

Promotion = 50%

Out of category 35, and 36 having 3 years experience as Manager (Production) or Dairy Engineer. Must at least be B.Sc. (Dairy Technology or B.E. or M.Sc. Dairy Engineering.

✓ 35. Manager (Production)

Direct = Nil.
Promotion = 100%

Out of category 37 having 7 years experience as Deputy Manager (Production), must at least be B.Sc. (D.T.).

36. Dairy Engineer

Direct = Nil
Promotion = 100%

Out of category 41 having 7 years experience as Junior Dairy Engineer. Must at least be B.Sc. Engineering or M.S. Dairy Engineering.

37. Deputy Manager
(Production)

Direct = Nil.
Promotion = 100%

Out of joint seniority list of category 39 of Annexure A and 21 of Annexure C, having 7 years experience as Shift Manager. Must be at least I.D.D. (D.T.).

✓ 38. Deputy Manager
(Quality Control)

Direct = Nil.
Promotion = 100%

Out of category 40 having 7 years experience as Quality Control Officer. Must be at least B.Sc. (DT) or M.Sc. Dairy Bacteriology or M.Sc. Dairy Chemistry or M.Sc. (Chemistry).

39. Shift Manager

Direct = 50%

B.Sc. (DT) Marks 60% or above or
M.Sc. Food Technology Marks 60% or
above, having 3 years experience in
processing of milk and Milk products.

Promotion = 50%

Out of category 42 of Annexure A &
22 of Annexure C having 7 years
experience as Dairy Supervisor. Must
atleast be I.D.D. (D.T).

40. Quality Control Officer

Direct = 50%

B.Sc. Chemistry/Microbiology marks
60% or above with 5 years experience
of quality control of milk and milk
products.

or

M.Sc. (Dairy Chemistry) marks 60%
or above. M.Sc. Bacteriology marks
60% or above or M.Sc. Chemistry,
marks 60% or above, 3 years
experience in quality control of
milk and milk products.

Promotion = 50%

Out of joint list of category, 44 &
45 of Annexure A and category 23 of
Annexure C, 7 years experience as
Technical Assistant or Bacteriolo-
gist. Must atleast be B.Sc.
Chemistry.

41. Junior Dairy Engineer

Direct = 50%

Degree in Dairy Engineering Marks
60% or above or B.E. Mechanical
marks 60% or above.

Promotion = 50%

Out of category 43 having 7 years
experience as Foreman. Must atleast
be Diploma Holder in Electrical or
Mechanical or Refrigeration or
Boiler.

42. Dairy Supervisor

Direct = 50%

B.Sc. (D.T) or

I.D.D. (D.T) with 5 years experience in processing of milk and milk products.

Promotion = 50%

Out of category 48, having 5 years experience as Assistant Dairy Supervisor. Must atleast be I.D.D (D.T).

43. Foreman

Direct = 50%

Diploma in Electrical/Mechanical/Refrigeration/Electronics with 3 years experience in the respective trade in an organisation of repute.

Promotion = 50%

Out of category 47 having 7 years experience as Mechanic in the respective trade or Liquid Nitrogen Plant Operator. Must atleast be Diploma Holder or I.T.I Certificate.

44. Technical Assistant

Direct = 75%

B.Sc. with Chemistry/marks 60% or above. 3 years experience in quality control of milk and milk products.

or

M.Sc. Dairy Chemistry. Marks 60% or above.

Promotion = 25%

Out of category 51 having 7 years experience as Laboratory Assistant. Must atleast be B.Sc. Chemistry.

45. Bacteriologist

Direct = 100%

M.Sc. Bacteriology marks 60% or above.

Promotion = Nil.

46. Senior Boiler Attendant

Direct = Nil

- 2
47. Mechanic/LN
Plant Operator
- Promotion = 100%
- Out of category 50 having 7 years experience as Boiler Attendant. Must atleast be possessing Certificate of competency 1st Class issued by Chief Boiler Inspector.
- Direct = Nil
Promotion = 100%
- Out of category 49 of Annexure A and 25 of Annexure C having 7 years experience in respective trade as Fitter or Junior Mechanic or Compressor Operator. Must atleast possess I.T.I. Certificate of respective trade or matric.
48. Assistant Dairy Supervisor.
- Direct = 100%
Indian Dairy Diploma (D.T) marks 60% or above.
- Promotion = Nil.
49. Fitter, Junior—
Mechanic, Compressor Operator.
- Direct = 100%
Matric with I.T.I. in the respective trade.
- or
- Matric with 5 years experience in respective trade.
- Promotion = Nil.
50. Boiler Attendant
- Direct = 100%
- Matric with B.Competency/Class II Certificate issued by Chief Inspector of Boiler.
- Promotion = Nil.
51. Laboratory Assistant
- Direct = 100%
- B.Sc. with Chemistry or Matric marks 60% with Chemistry and Physics.
- Promotion = Nil.
52. Plant Operator (Dairy).
- Direct = Nil.
Promotion = 100%
- Out of category 54 of Annexure A having 7 years experience as

Dairyman. Must atleast be Matric, with N.I.T. certificate or ND DB.

53. Welder

Direct = 100%

Middle pass having proficiency in the trade.

Promotion = Nil.

54. Dairyman

Direct = 100%

Middle pass.

Promotion = Nil.

F. PROCUREMENT & INPUT

55. Project Officer

Direct = 50%

Graduate in veterinary science marks 60% or above, 10 years experience out of which, 5 years in a senior position in a Dairy Co-operatives on Anand pattern.

or

B.Sc. Dairying (D.T or D.H) marks 60% or above, having 10 years experience, out of which 5 years in a senior position in a Dairy Co-operative on Anand Pattern.

or

M.B.A. 60% marks or above with specialisation in marketing or personal management having 10 years experience out of which 5 years in Dairy line.

or

Masters Degree in Veterenary Science with 7 years experience out of which 5 years in a senior position in a Dairy Cooperative on Anand pattern.

Promotion = 50%

Out of category 58 of Annexure A and category 14 and 28 of Annexure C with 7 years experience as Artificial Insemination Officer or Senior Milk Procurement Officer. Must atleast be Graduate in

- Veterinary Science or B.Sc. Dairyig
DT or DH or M.B.A.
56. Manager Semen Bank-
cum-Training Centre
- Direct = 100%
- Graduate in Veterinary Science marks 60% or above with diploma in forzen semen technology. 10 years experience in frozen semen technology out of which 5 years in a senior position.
- or
- Master Degree in Veterinary Gynaecology/Animal Breeding/Animal Production with 60% marks or above & with 5 years experience in frozen semen technology.
- Promotion = Nil
57. Manager (MEAF)
- Direct = 100%
- Graduate in Veterinary Science marks 60% or above, with 10 years experience in management of buffaloes/cattle farm out of which 5 years in a senior position.
- or
- Master Degree in Veterinary Gynaecology, Animal Breeding/Animal production/Animal Genetics with 60% marks or above and with 5 years experience in management of buffaloes/cattle farm.
- Promotion = Nil
58. Artificial Insemination
Officer
- Promotion = 100%
- Out of category 59 with 7 years experience as Veterinary Officer, Must atleast be Graduate, in Veterinary Science.
59. Veterinary Officer
- Direct = 100%
- Graduate in Veterinary Science marks 60% or above. Preferably may be taken on deputation from some Union.
- Promotion = Nil.

60. Milk Procurement Officer
- Direct = 100%
B.Sc. Dairying (DT or DH) with marks 60% or above atleast 3 years experience in milk procurement & extension work in supervisory capacity in dairy cooperatives on Anand Pattern.
- or
- ID.D (DT/DH) marks 60% or above and 7 years experience in milk procurement & extension work in supervisory capacity in Dairy Cooperatives on Anand Pattern.
- or
- B.Sc. Agriculture, marks 60% or above, atleast 3 years experience in Milk procurement & extension work in supervisory capacity in Dairy co-operative on Anand Pattern Preference will be given to Assistant Milk Procurement Officers working in Milk Unions in Haryana. (This Officer should preferably be taken on deputation from some Union).
- Promotion = Nil.
61. Agronomist
- Direct = Nil.
Promotion = 100%
- Out of joint seniority list of category 30 of Annexure C of Unions having 3 years experience as Fodder Development Officer. Must atleast be B.Sc. Agriculture.
62. Assistant Fodder Development Officer
- Direct = Nil
Promotion = 100%
- Out of category 63 having 7 years experience as Field Assistant. Must atleast be B.Sc. Agriculture.
63. Field Assistant (MEAF)
- Direct = 100%
B.Sc. Agriculture
Promotion = Nil.
64. Livestock Assistant, MEAF.
- Direct = 100%
Matric with one year diploma in Livestock.
- or

I.D.D. (D.H) with experience in Artificial insemination or cattle management.

Promotion = Nil.

G. COOPERATION

65. Institutional Development Officer

Direct = 100%
Post Graduate in Dairying, Veterinary Science, Agriculture Science, Economics, Statistics, Commerce, Business Administration, marks 50% or above with 7 years experience in a senior position connected with supervision and organisation of cooperatives societies.

Promotion = Nil.

65A Deputy Registrar Co-operative society

May be taken on deputation from Cooperation Department.

→ 66. Inspector Cooperative Society

May be taken on deputation from Cooperation Department.

← H. Marketing
67. Director (Marketing)

Direct = 100%

M.Com/M.A. Economics marks 60% or above with Master of Business Administration and 10 years experience in Planning & Marketing of Dairy Product in an undertaking of standing and repute.

Promotion = Nil

~~H. MARKETING~~

68. Manager (Sales)

Direct = Nil
Promotion = 100%

Out of category 69 having 7 years experience as Sales Officer. Must atleast be Graduate.

69. Sales Officer

Direct = 50%

Graduate or MBA marks 60% or above with 5 years experience in sale of consumer goods.

Promotion = 50%

Out of category 70 having 7 years experience as Sales Representative. Must atleast be Graduate.

70. Sales Representative

Direct = Nil
Promotion = 100%

Out of category 72 having 7 years experience as Salesman/Sales girl/Sales Clerk. Must atleast be Matriculate.

71. Commercial Artist

Direct = 100%
Promotion = Nil.

Matric having sound knowledge of commercial art.

72. Sales Girl/Sales-man/
Sales Clerk

Direct = 100%
Matric marks 60% or above

or

Graduate.

Promotion = Nil.

I. CIVIL ENGINEERING

73. Executive Engineer

Direct = 50%
B.E. (Civil) with 60% marks or above and 5 years experience in the related line.

Promotion = 50%

Out of category 74 having 7 years experience as S.D.O. Civil. Must atleast be B.E. (Civil).

74. Sub-Divisional Officer
(Civil)

Direct = 50%
B.E. Civil marks 60% or above.

or

Diploma Civil Engineering with 10 years experience as Junior Engineer.

Promotion = 50%

Out of category 75 and 76 having 10 years experience as Junior Engineer & Draftsman. Must be atleast Diploma Holder in a Civil Engineering/Draftsman.

HARYANA DAIRY COOPERATIVE'S STAFF SERVICES RULES, 1988

ANNEXURE-CCategories of posts in the Service of a Union

<u>Sr.No.</u>	<u>Category of Post</u>	<u>Pay Scale</u>
1.	Chief Executive Officer	Scale of Officer holding the post on deputation.
B. <u>ADMINISTRATION & ACCOUNTS</u>		
2.	Assistant Accounts Officer	2000-3200
3.	Accountant	1400-2600
4.	Assistant	- do -
5.	Store-keeper	- do -
6.	Accounts Clerk	1200-2040
7.	Driver	1200-2040 + Special pay of Rs.100/- for jeep-car drivers.
8.	Clerk	950-1500
9.	Junior Store-keeper	- do -
10.	Steno-typist	950-1500 + Special pay as applicable to Govt. Employee.
11.	Peon/Watchman/Gardner/Helper/Sweeper/Store/Attendant/Laboratory/Attendant.	750-940 + Special allowance to sweepers as per, Govt Instructions.
C. <u>MONITORING</u>		
12.	Management Information System Officer	1640-2900
13.	Management Information System Assistant	1400-2600
D. <u>PROCUREMENT</u>		
14.	Senior Milk Procurement Officer	2200-4000
15.	Milk Procurement Officer	2000-3500
16.	Assistant Milk Procurement Officer	1640-2900

17.	Extension & Milk Procurement Assistant	1400-2600
18.	Mechanic (Milkotestor)	1400-2600
19.	Dairy Extension Worker	950-1500
20.	Projector Operator	- do -

E. PROCESSING

21.	Shift Manager	2000-3500
22.	Dairy Supervisor	1640-2900
23.	Technical Assistant	- do -
24.	Assistant Dairy Supervisor	1400-2600
25.	Compressor Operator	950-1500
26.	Laboratory Assistant	950-1500
		Pay scale of Rs.1400-2600 to Laboratory Assistants shall remain personal. No recruitment in this scale in future.
27.	Dairyman	750-940

F. INPUT

28.	Artificial Insemination Officer	2200-4000
29.	Veterinary Officer	2000-3500
30.	Fodder Development Officer	2000-3200
31.	Livestock Assistant	1400-2600

PAY SCALES

1.	2200-4000	=	2200-75-2800-EB-100-4000
2.	2000-3500	=	2000-60-2300-EB-75-3200-100-3500
3.	2000-3200	=	2000-60-2300-EB-75-3200
4.	1640-2900	=	1640-60-2600-EB-75-2900
5.	1400-2600	=	1400-40-1600-50-2300-EB-60-2600
6.	950-1500	=	950-20-1150-EB-25-1500
7.	750-940	=	750-12-870-EB-14-940

Haryana Dairy Cooperative Staff Services Rules, 1988

Annexure-D

(Referred to in Rule-4)

Qualifications and Nature of Recruitment in a Union

<u>Sr.No.</u>	<u>Description of Post</u>	<u>Nature of Recruitment for a Union</u>
---------------	----------------------------	--

A. GENERAL

1.	Chief Executive Officer	Officer to be deputed by the Federation
----	-------------------------	---

B. ADMINISTRATION & ACCOUNTS

2.	Assistant Accounts Officer	Officer to be deputed by the Federation.
----	----------------------------	--

3.	Accountant	Direct = 50%
----	------------	--------------

B.Com. marks 55% or above with 3 years post qualification experience in maintenance of accounts.

or

M.Com. marks 55% or above with one year post qualification experience in maintenance of accounts.

Promotion = 50%

Out of category 6 having 7 years experience as Accounts Clerk.

4.	Assistant	Direct = Nil Promotion = 100%
----	-----------	----------------------------------

Out of category 8 having 7 years experience as Clerk.

5.	Store Keeper	Direct = 50%
----	--------------	--------------

Graduate with Diploma in Material Management or Diploma in Store and Inventory Control.

Promotion = 50%

Out of category 9 having 7 years experience as Junior Store

- Keeper, Store Clerk, Store Care-taker, Purchase Clerk.
6. Accounts Clerk
 Direct = 100%
 B.Com. marks 50% or above.
- or
- B.A./B.Sc. having 5 years experience in maintenance of accounts in the Union.
- Promotion = Nil.
7. Driver
 Direct = 100%
- Middle with driving licence both for heavy and light vehicles with 5 years experience of driving.
- Promotion = Nil.
8. Clerk
 Direct = 75%
- Matriculation marks 60% or above.
- or
- Graduate.
 Minimum type speed of 35 w.p.m.
 Promotion = 25%
- Out of category 11 having 7 years experience on acquiring matriculation as peon, watchman, gardner, helper, sweeper, store attendant, lab.attendant.
9. Junior Store Keeper/Store Clerk/Store Care taker/
 Purchase Clerk
 Direct = 100%
 Matric with marks 60% or above.
- or
- Graduate.
 Promotion = Nil.
10. Steno-typist
 Direct = 100%
- Graduate with minimum type speed in English 35 w.p.m. and shorthand speed of 80 w.p.m. & in Hindi type speed 30 w.p.m. & shorthand 64 w.p.m.
- Promotion = Nil.
11. Peon, Watchman, Gardner,
 Helper, Sweeper, Store
 Direct = 100%

Attendant, Lab. ~~Assistant~~ Middle pass except in case of Gardner, Watchman, Sweeper who may be literate only.

Promotion = Nil.

C. MONITORING

12. Management Information System Officer Direct = 100%
M. Sc. Dairy Economics or M.A. Mathematics/ Statistics/ Economics or M.B.A. or Post Graduate Diploma in Management equivalent to M.B.A. with specialisation in M.I.S. or B.Sc. Dairying with one year experience in M.I.S.

13. Management Information System Assistant Direct = 100%
M.A. Mathematics / Statistics / Economics 50% marks or above.

or

Graduate with Mathematics/Statistics/Economics 60% marks or above.

D. PROCUREMENT

14. Senior Milk Procurement Officer Direct = Nil
Promotion = 100%
Out of category 15 having 7 years experience as Milk Procurement Officer. Must atleast be I.D.D. (D.T) or (D.H).

15. Milk Procurement Officer Direct = 25%
B.Sc. (DT) or B.Sc. (DH) marks 60% or above. 3 years experience in Milk Procurement & extension work in supervisory capacity in Dairy Cooperatives on Anand Pattern or I.D.D. (D.T) or I.D.D. (D.H) with 60% marks or above. 7 years experience in Milk Procurement and Extension work in Supervisory Capacity in Dairy Cooperatives on Anand Pattern.

Promotion = 75%

Out of category 16 having 7 years

- experience as Assistant Milk Procurement Officer. Must at least be B.Sc. (D.T) or B.Sc. (D.H) or I.D.D (D.T) or I.D.D (D.H) or Diploma in Live Stock.
- Direct = 50%
- B.Sc. (D.T) or B.Sc. (D.H).
- or
- I.D.D. (D.T) or I.D.D. (D.H)
- 3 years experience in Milk Procurement and Extension work on Anand Pattern.
- Promotion = 50%
- Out of category 17 and 31 having 7 years experience as Extension and Milk Procurement Assistant or Live Stock Assistant.
- Direct = 50%
- Graduate marks 55% or above. Direct recruitment will only be made when all eligible Dairy Extension Workers are promoted.
- Promotion = 50%
- Out of category 19 having 7 years experience as Dairy Extension Worker. Must at least be Matriculate.
- Direct = 100%
- Matric with Diploma in Electronics 60% marks or above.
- No further recruitment to be made
- Direct = 100%
- Matriculation with cinematograph operating licence.
- Promotion = Nil.

16. Assistant Milk Procurement Officer

17. Extension & Milk Procurement Assistant

18. Mechanic (Milkotester)

19. Dairy Extension Worker

20. Projector Operator

21. Shift Manager

E. PROCESSING

Direct = 100%

B.Sc. (D.T) marks 60% or above.

or

B.Sc. Food Technology marks 60% or above. 3 years experience in processing of milk and milk products.

Promotion = Nil

Direct = 50%

22. Dairy Supervisor

B.Sc. (D.T) or I.D.D. (D.T) 3 years experience of processing of Milk and products.

Promotion = 50%

Out of Category 24 having 7 years, experience as Assistant Dairy Supervisor must atleast be I.D.D. (D.T.).

Direct = 75%

23. Technical Assistant

B.Sc. with marks 60% or above. 3 years experience in Quality Control of Milk and Milk Product.

or

M.Sc. Dairy Chemistry/Dairy Microbiology marks 60% or above.

Promotion = 25%

Out of category 26 having 7 years experience as Laboratory Assistant Must atleast be B.Sc. Chemistry.

24. Assistant Dairy Supervisor

Direct = 100%

I.D.D. (D.T) marks 60% or above.

Promotion = Nil

25. Compressor Operator

Direct = 100%

Matriculation with I.T.I. Certificate in respective trade.

or

Matriculation with 5 years

- experience in the trade.
26. Laboratory Assistant Direct = 33 1/3%
B.Sc. with Chemistry marks 55% or above.
or
Matric marks 60% or above with Chemistry & Physics.
Promotion = 66-2/3%
Out of category 27 having 7 years experience of Dairyman. Must at least be Matriculate with Chemistry & Physics.
27. Dairyman Direct = 100%
Middle pass.
Promotion = Nil

F - INPUT

28. Artificial Insemination Officer Direct = Nil
Promotion = 100%
Out of category 29 having 7 years experience as Veterinary Officer. Must at least be B.VSC. & A.H.
29. Veterinary Officer Direct = 100%
B.VSC & A.H. 60% marks or above
Promotion = Nil
30. Fodder Development Officer Direct = 100%
B.Sc. Agriculture marks 60% or above having Post Graduation in Agronomy or soil Sciences or Dairying (Forage-Production).
Preference will be given to Person working as Assistant Fodder Development Officer or Field Assistant in the units of Federation.

Promotion = Nil

31. Live Stock Assistant

Direct = 100%

Matric with one year diploma in
Live-Stock or I.D.D. (D.H.) with
experience in artificial
Insemination or cattle management

Promotion = Nil

Haryana Dairy Cooperative's Staff Service Rules 1988ANNEXURE - EReferred to in Rule - 42.2

Authorities competent to sanction various kinds of leave to the employees in Annexure - A.

Sr. No.	Nature of leave	Authority Competent to sanction leave	Extent of Power
1.	<u>CASUAL LEAVE</u>		
i)	General Manager, Milk Plant	Managing Director	Full powers
ii)	Farm Manager, MEAF	-do-	
iii)	Manager, Semen Bank Rohtak	-do-	
iv)	Divisional Head at Hqrs.	-do-	
v)	Personal Staff to MD	-do-	
vi)	Other employees at Hqrs. (without substitute)	Divisional Head at Hqrs.	Full power
vii)	Other employees at Hqrs. (with substitute)	C.A.O.	-do-
viii)	Other employees of Milk Plant.	Officer incharge of the section in the plant.	Upto 3 days.
		G.M. Milk Plant	Full Power
ix)	Employees of MEAF, Bhiwani	Farm Manager	Full Power
x)	Employees of Semen Bank	Manager, Semen Bank	Full Power
2.	<u>EARNED LEAVE</u>		
	Maternity Leave, Half pay leave, Commuted leave, Extra-ordinary leave.		
i)	Employees in basic pay scale of Rs.2000/- or above	Managing Director	Full Powers
ii)	Employees drawing consolidated pay of Rs.2500/- or above.	-do-	

	iii) Chief Executive Officer of Milk Union(s).	-do-	
	iv) Personal Staff of MD	-do-	
	v) Employees in basic scale below Rs.2000/- at Hqrs.	Chief Admn. Officer	Full Powers
	vi) Employees drawing consolidated pay below Rs.2500/- at Hqrs.	-do-	
	vii) Employees working in Milk Plant	General Manager Milk Plant.	60 days without substitute.
	viii) Employees working in MEAF, Bhiwani.	Farm Manager MEAF.	-do-
	ix) Employees working in Semen Bank, Rohtak.	Manager, Semen Bank, Rohtak.	-do-
	x) Employees working in Milk Plants/MEAF Bhiwani/SBTC Rohtak beyond 60 days .. with substitute	Chief Admn. Officer	Full Powers.
4.3	Study Leave	Personnel committee.	-do-
4.4	<u>Leave Encashment</u>		
	All employees in Headquarter and field.	Managing Director.	-do-

Authorities competent to sanction various types of leave to employees in Annexure-C.

1. Casual Leave
 - i) Chief Executive Officer
 - ii) All employees of the Union.
2. Earned Leave Maternity Leave, Half Pay Leave and Commuted Leave
 1. All employees of the Union except CEO & AAO.
 2. Extra Ordinary leave all employees of the Union
 3. Study leave all employees of the Union.

Chairman	Full Powers.
Chief Executive Officer.	-do-

Chief Executive Officer	Full Powers.
-------------------------	--------------

Chief Executive Officer	Upto 60 days.
-------------------------	---------------

Personnel Committee.	Full Powers.
----------------------	--------------

Personnel Committee.	Full Powers.
----------------------	--------------

- | | | | |
|----|--|------------------------------------|--------------|
| 5. | Leave encashment all employees of the Union. | Personnel Committee. | Full Powers. |
| 6. | All types of leave except study leave to CEO/AAO | Managing Director. | Full Powers. |
| 7. | Study leave to Chief Executive Officer/AAO | Personnel Committee. of Federation | Full Powers. |

Haryana Dairy Cooperative Staff Service Rules, 1988ANNEXURE-F.I.For Group 'A' ServiceAnnual Confidential ReportPart-I.To be filled by the Administrative Branch

1. Year under Report :
2. Name of the Officer :
3. Designation & place of posting :
4. Scale of Present Post :
5. Qualifications :
6. Period spent on present job :
7. Name and Designation of reporting officer :
8. Name and Designation of Reviewing officer :
9. Name and Designation of Accepting officer. :

Part-II.

10. To be filled by the officer reported upon :
- a) Brief description of duties :
- b) Financial & Physical targets and achievements against each.
- c) Constraints for short falls if any
- d) Description of outstanding work done, if any

Part-III.

11. Assessment of reporting officer
- a) Job knowledge :
 - b) Quality of work :
 - c) Industrious and conscientiousness :
 - d) Dependability :
 - e) Leadership :
 - f) Discipline control and organising capacity :
 - g) Communication oral and written :
 - h) Interpersonal relationship :
 - i) Initiative and creativity :
 - j) Reputation for honesty :
 - k) Capacity and intelligence :
 - l) Promptness in disposal of work :
 - m) Willingness to accept responsibility :
 - n) Decision making judgement :
 - o) Outstanding work done during the year :
 - p) Special quality if any :
 - q) Special defect if any :
 - r) Comments on self appraisal in part-II :
 - s) Fitness for promotion (Fit) (Not yet) (Unfit) :
 - t) Grading (Outstanding, very good, good, average, below average. :

Signature
Designation

Part-IV.

Remarks of the Reviewing Officer

Comments on self appraisal in Part II and assessment of Reporting officer in Part III also mention special characteristics/abilities for special assignment if any.

Signature
Designation

Part-V.

Remarks of the Accepting Officer

Signature
Designation

Haryana Dairy Cooperative's staff service Rules, 1988ANNEXURE F-2For Group B ServiceAnnual Confidential Report

1. Year under report :
 2. Name of the employee :
 3. Designation and place of posting :
 4. Scale of post :
 5. Qualifications :
 6. Period spent in present job :
 7. Name and designation reporting officer :
 8. Name and designation reviewing officer :
 9. Name and designation of Accepting Officer :
-
10. Reporting Officer's assessment :
 - a) Job knowledge :
 - b) Quality of work :
 - c) Industrious and conscientiousness :
 - d) Dependability :
 - e) Leadership :
 - f) Discipline and control or organising capacity :
 - g) Interpersonal relationship :
 - h) Communication oral and written :
 - i) Initiative and creativity :
 - j) Reputation for honesty :
 - k) Capacity and intelligence :

- l) Promptness in disposal of work :
- m) Drafting :
- n) Special qualities if any :
- o) Special defect if any :
- p) Outstanding job done during the year :
- q) Fitness for promotion (fit) (not yet) (unfit)
- r) Grading
(Outstanding, very good, good, average, below average)

Signature
Designation

11. Remarks of Reviewing Officer

Signature
Designation

12. Remarks of Accepting Officer

Signature
Designation

Haryana Dairy Cooperative's Staff ServiceRules, 1988For Group C ServiceANNEUXRE F-3Annual Confidential Report

1. Year under Report :
 2. Name of the employee :
 3. Designation and place of posting :
 4. Scale of post :
 5. Qualifications :
 6. Period spent on present job :
 7. Name and designation of reporting officer :
 8. Name and designation of reviewing officer :
 9. Name and designation of accepting officer :
-
10. Reporting Officer's Assessment :
 - a) Industry and conscientiousness :
 - b) Hand writing and neatness :
 - c) Capacity and intelligence :
 - d) Knowledge of rules and instructions :
 - e) Punctuality and regularity :
 - f) Reputation for honesty :
 - g) Relations with public, subordinates and seniors :
 - h) Promptness and disposal of work :
 - i) Drafting :
 - j) Other qualities if any :

k) Other defects if any _____ :

l) Grading _____ :

(Outstanding, very good, good,
average, below average)

Signature
Designation

11. Remarks of Reviewing Officer

Signature
Designation

12. Remarks of Accepting Officer

Signature
Designation

Haryana Dairy Cooperative's Staff Service Rules 1988Annexure-F-4for Group D serviceANNUAL/CONFIDENTIAL REPORT

- | | | |
|----|---|---|
| 1. | Year under report | = |
| 2. | Name of the employee | = |
| 3. | Designation & place of posting | = |
| 4. | Scale of post | = |
| 5. | Qualifications | = |
| 6. | Period spent on present job | = |
| 7. | Name & designation of Reporting Officer | = |
| 8. | Name & designation of Reviewing Officer | = |
| 9. | Name & designation of Accepting Officer | = |
-
- | | | |
|-----|---|---|
| 10. | <u>Reporting Officer Assessment</u> | |
| a) | Loyalty & devotion to duty | = |
| b) | Industry | = |
| c) | Honesty | = |
| d) | Other qualities if any | = |
| e) | Defects if any | = |
| f) | Grading
(outstanding, very good, good, average
below average) | |

Signature
Designation

10. Remarks of reviewing Officer

Signature
Designation

11. Remarks of Accepting Officer

Signature
Designation

Haryana Dairy Cooperative's Staff Service Rules, 1988
(Reference to in Rule 54.2)

ANNUAL CONFIDENTIAL REPORT

<u>S. No.</u>	<u>Category of Post</u>	<u>Reporting Authority</u>	<u>Reviewing Authority</u>	<u>Accepting Authority</u>	<u>Appellate Authority</u>
<u>FEDERATION</u>					
<u>A. GENERAL</u>					
1.	Managing Director	As per Government instructions.			
<u>B. ADMINISTRATION</u>					
2.	Chief Administrative Officer	As per Government instructions.			
3.	Manager (Personnel & Administration)	CAO	-	MD	PERSONNEL COMMITTEE
4.	Purchase Officer	GM,MP	CAO	MD	-do-
5.	Assistant Personnel Officer . HQ	M(P&A)	CAO	MD	-do-
	FIELD	GM,MP	CAO	MD	-do-
6.	Labour Welfare Officer	M(P&A)	CAO	MD	-do-
7.	Store Officer	CAO		MD	-do-
8.	Personal Assistant (Chairman/MD).	-	-	Chairman MD	-do-
9.	Assistant	Officer Incharge	Concerned Div.Head or	MD	-do-
		GM, MP/MSB/MF in field units.			
10.	Store Keeper (Purchase Assistant)	-do-	-do-	MD	-do-
11.	Stenographer	-do-	-	MD	-do-
12.	Security Officer	GM,MP	D(P)	MD	-do-
13.	Driver HQ	CAO	-	MD	-do-

1	2	3	4	5	6
	FIELD	GM,MP/ MSB/MF Officer Incharge	D(P) -	MD Concerned Div. Head at Hqrs. OR GM,MP/MSB/ MF.	-do- MD
14.	Junior Store Keeper				
15.	Clerk	-do-	-	-do-	-do-
16.	Steno-Typist	-do-	-	-do-	-do-
17.	Guest House Keeper/ Cook.	-do-	-	GM,MP	-do-
18.	Jamadar/Daftri/ Machine Operator	-do-	-	CAO/ MD	MD PERSONNEL COMMITTEE
19.	Security Havildar	s.o.	-	GM,MP	MD
20.	Peon/Sweeper/Watchman/ Garnder/Labourer/ Gatemen/Van Attendant/ Bull Attendant/Sewerman Helper etc.	Officer Incharge	-	Concerned Div. Head or GM,MP/ MF/MSB.	-do-
C. <u>ACCOUNTS</u>					
21.	Manager(Accounts & Finance).				
	FIELD UNITS	GM,MP &	-	MD	PERSONNEL COMMITTEE
	HQ.	M(A&F)	-	MD	-do-
22.	Deputy Manager (Accounts)				
	FIELD UNITS	GM,MP & M(A&F)	-	MD	PERSONNEL COMMITTEE
23.	Accounts Executive				
	FIELD UNITS	GM, MP & M (A&F)	-	MD	-do-
	HQ.	M (A&F)	-	MD	-do-
24.	Assistant Accounts Officer/Audit Officer				
	FIELD UNITS	GM,MP/ MF/MSB		MD	-do-
	HQ	&(M&F)	-	MD	-do-

1	2	3	4	5	6
25.	Senior Accountant				
	FIELD UNITS	Officer	GM,MP &		-do-
		I/C.	M(A&F)	MD	
	HQ	-do-	M(A&F)	MD	-do-
26.	Accountant				
	FIELD UNITS	-do-	GM,MP&		-do-
			M(A&F)	MD	
	HQ.	-do-	M(A&F)/MD		-do-
			M(P&M)		
27.	Accounts Clerk				
	FIELD UNITS	Officer	GM,MP	MD	PERSONNAL
		I/C	MAF		COMMITTEE
	HQ.	-do-	M(A&F)	MD	-do-
D. <u>PLANNING & MONITORING</u>					
28.	Manager Planning & Monitoring			MD	-do-
29.	Deputy Manager (Planning & Monitoring).	M(P&M)		MD	-do-
30.	Senior Management Information System Officer	-do-		MD	-do-
31.	Management Information System Officer.	-do-		MD	-do-
E. <u>PRODUCTION AND PROJECTS</u>					
32.	Director (Production & Projects)			MD	-do-
33.	General Manager Projects	D(P)		MD	-do-
34.	General Manager, Milk Plant.	-do-		MD	-do-
35.	Manager (Production)	GM,MP	D(P)	MD	-do-
36.	Dairy Engineer	GM,MP	D(P)	MD	-do-
	FIELD UNITS				
	HQ	D(P)		MD	-do-
37.	Deputy Manager Production,		D(P)	MD	-do-
		GM,MP			
38.	Deputy Manager Quality Control	GM,MP	D(P)	MD	-do-

1	2	3	4	5	6
39.	Shift Manager	M(P)	GM,MP & D(P)	MD	-do-
40.	Quality Control Officer				
	FIELD UNITS	GM,MP	D(P)	MD	-do-
	HQ	D(P)	-	MD	-do-
41.	Junior Dairy Engineer	DE - OR -	GM,MP &D(P)	MD	-do-
42.	Dairy supervisor	MP/DM(P)	GM,MP	D(P)	MD
43.	Foreman	DE - OR -	GM,MP	-do-	-do-
44.	Technical Assistant	QCO/DM(QC)	-do-	-do-	-do-
45.	Bacteriologist	-do-	-do-	-do-	-do-
46.	Senior Boiler Attendant	DE	-do-	-do-	-do-
47.	Mechanic	-do-	-do-	-do-	-do-
48.	Assistant Dairy Super- visor	M(P)/DMP	-do-	-do-	-do-
49.	Fitter/Compressor operator/Junior Mechanic	Foreman	DE	GM,MP	(D(P))
50.	Boiler Attendant	-do-	-do-	-do-	-do-
51.	Laboratory Assistant	TA	QCO/ DM(QC)	-do-	-do-
52.	Plant operator(Dairy)	SM	MP/ DM(P)	-do-	-do-
53.	Welder	Foreman/ officer I/C	DE	-do-	-do-
54.	Dairyman	SM	MP/ DM(P)	-do-	-do-
	<u>F. PROCUREMENT AND INPUT</u>				
55.	Project Officer(CEO)	Chairman of concened Milk Union	-	MD	Personnel Committee
56.	Manager, SBTC			MD	-do-
57.	Manager, MEAF			MD	-do-

1	2	3	4	5	6
58.	Artificial Insemination officer	MF		MD	-do-
59.	Veterinary Officer	MSB		MD	-do-
60.	Milk Procurement officer	Officer I/C		MD	-do-
61.	Agronomist	MF		MD	-do-
62.	Assistant Fodder Development Officer	Agronomist MF		MD	-do-
63.	Field Assistant MEAF Semen Bank	Agronomist MF MSB		MD MD	-do- -do-
64.	Livestock Assistant	AIO	MF	MD	-do-
<u>G. COOPERATION</u>					
65.	Assistant Registrar	Office I/C		MD	-do-
66.	Inspector Cooperative Societies	ARCS	Officer I/C	MD	-do-
<u>H. MARKETING</u>					
67.	Director Marketing	-	-	MD	-do-
68.	Manager Sales HQ Field Units	DM GM(P)	DM	MD MD	-do- -do-
69.	Sales Officer HQ/Sales Depots Milk Units	Officer I/C GM,MP	DM	MD MD	Personnel Committee -do-
70.	Sales Representative Milk Plants Sale Depots	-do- - -do-	GM,MP - -	DM - DM	MD - -do-
71.	Commercial Artist	Sales Officer	Next Higher Officer	-do-	-do-
72.	Saleman/Sales/Girl Sales Clerk	Officer I/C	-do-	-do-	-do-
<u>E. CIVIL ENGINEERING</u>					
73.	Executive Engineer	D(P)	-	MD	Personnel Committee
74.	Sub-Divisional Officer (Civil)	XEN	D(P)	MD	-do-

75.	Junior Engineer(Civil)	XEN	D(P)	MD	-do-
76.	Draftsman (Civil)	DE/XEN	D(P)	MD	-do-
77.	Plumber	SDO(C)	XEN	DP	MD
78.	Carpenter	-do-	-do-	-do-	-do-
79.	Mason	-do-	-do-	-do-	-do-

MILK UNIONS

A. GENERAL

1.	Chief Executive Officer	Chairman MU	-	MD	Personnel Committee of the Fedration
----	-------------------------	----------------	---	----	---

B. ADMINISTRATION AND ACCOUNTS

2.	Assistant Accounts Officer	CEO& M(P&M)	-	MD	-do-
3.	Accountant	AAO	-	CEO	Personnel Committee of the Milk Union
4.	Assistant	Officer I/C	-	CEO -	-do- -
5.	Store Keeper	-do-	-	-do-	-do-
6.	Account Clerk	AAO	-	-do-	-do-
7.	Driver	Officer I/C	-	-do-	-do-
8.	Clerk	-do-	-	-do-	-do-
9.	Junior Store Keeper	-do-	-	-do-	-do-
10.	Steno-Typist	-do-	-	-do-	-do-
11.	Peon, Watchman, Gardner, Helper, Sweeper, Store- Attendant, Lab. Attendant etc.	-do-	-	-do-	-do-

C. MONITORING

12.	MIS Officer	-	-	CEO	Personnel Committee of Milk Union
-----	-------------	---	---	-----	--

13.	MIS Assistant	-	-	-do-	-do-
	<u>D. PROCUREMENT</u>				
14.	Senior Milk Procurement Officer	-	-	-do-	-do-
15.	Milk Procurement Officer	-	-	-do-	-do-
16.	Assistant Milk Procurement Officer	MPO/SMPO	-	-do-	-do-
17.	Extension and Milk Procurement Assistant	AMPO	MPO/SMPO	-DO-	-do-
18.	Mechanic(Milkotester)	MPO/SMPO	-	-do-	-do-
19.	Dairy Extension Worker	AMPO	MPO/SMPO	-do-	-do-
20.	Projector Operator	MPO/SMPO	-	-do-	-do-
	<u>E. PROCESSING</u>				
21.	Shift Manager	-	-	-do-	-do-
22.	Dairy Supervisor	Officer I/C	-do-	-do-	-do-
23.	Technical Assistant	-do-	-do-	-do-	-do-
24.	Assistant Dairy Supervisor	-do-	-	-do-	-do-
25.	Compressor Operator	-do-	-	-do-	-do-
26.	Laboratory Assistant	-do-	-	-do-	-do-
27.	Dairyman	-do-	-	-do-	-do-
28.	Artificial Insemination Officer		-	-do-	-do-
29.	Veterinary Officer	-	-	-do-	-do-
30.	Fodder Development Officer	-	-	-do-	-do-
31.	Live Stock Assistant	AIO	-	-do-	-do-

ABBREVIATIONS USED IN THE ANNUEXURE G.FEDERATION.

1. Managing Director	MD
2. Chief Admn. Officer	CAO
3. Manager Personnel and Administration	MPA
4. General Manager (Milk Plants)	GM(MP)
5. Manager(Farm)	MF
6. Manager Semen Bank-Cum-Training Centre.	MSB
7. Manager (Accounts and Finance)	M(A&F)
8. Dairy Engineer	DE
9. Executive Engineer	XEN
10. Director (Production & Project)	D(P)
11. Director Marketing	DM
12. Manager Production	MP
13. Deputy Manager Production	DMP
14. Shift Manager	SM
15. Quality Control Officer.	QCO
16. Assistant Register Cooperative Societies.	ARCS
17. Deputy Manager (Quality Control)	DMQC
18. Sub Divisional Officer (Civil)	SDO(C)

MILK UNIONS.

1. Chief Executive Officer	CEO
2. Artificial Insemination Officer	AIO
3. Assistant Accounts Officer	AAO
4. Senior Milk Procurement Officer	SMPO
5. Milk Procurement Officer	MPO
6. Assistant Milk Procurement Officer	AMPO

Haryana Dairy Cooperative's Staff Service Rules 1988.

(Referred to in Rule 58)

Declaration of Moveable/Immoveable Property.

1. Name of the Employee :
 2. Designation :
 3. Annual Gross Income for the year under report :
 4. Date of Birth :

5. Details of moveable Property i.e. Cash, Gold, Jewellery, deposits, shares, certificates, units, insurance, policies, public provident fund, debentures, Motor-cycle, car, T.V. Refrigerator, Milk Cattle etc. of the value of Rs.2000/- each or more.

Sr.No.	Name of Item	Basic/ purchase price	Name of owner	Date and manner of acquisition during the year if any.	Remarks
--------	--------------	-----------------------------	------------------	--	---------

- i)
 ii)
 iii)
 iv)
 v)
 vi)

6. Loans Recoverable

Sr.No.	Amount of Loan	Who Advanced	To whom Advanced	Nature of security taken	Loans Advanced during the year	Total amount recoverable	Remarks
1.	2.	3.	4.	5.	6.	7.	8.

- i)
 ii)
 iii)
 iv)
 v)
 vi)
 vii)

ANNUEXRE-H

7. Loans debts and other Liabilities :

Sr. No.	Amount of loan/ Liability	From whom borrowed	Who borrowed	Nature of security given	Loan debts liabilities under taken during the year	Total Loans/ debts/liabilities/Payable at the end of the year	Remarks
1.	2.	3.	4.	5.	6.	7.	8.

- (i)
- (ii)
- (ii)
- (iv)
- (v)

8. Immovable property i.e all interests in land and building, plots of a permanent nature whether ownership, mortgage or hereditary occupancy.

Sr. No.	Address where situated	Description i.e. plot area building	Basic value	How and when acquired by inheritance, Gift etc.	When acquired	Remarks
1.	2.	3.	4.	5.	6.	7.

- (i)
- (ii)
- (iii)
- (iv)
- (v)
- (vi)
- (vii)
- (.iii)

I certify that statement given above is true and correct to the best of my knowledge and belief and that it indicates all properties, in my name, in the name of my family members and other persons.

Signaute

Designation

To

1. The General Manager,
Milk Plant,
Ambala/Bhiwani/Ballegarh/Jind/Rohtak & Sirsa
2. Incharge,
Model Exotic Animal Farm,
Bhiwani
3. The Manager,
Semen Bank cum Training Centre,
Rohtak
4. All Sales Depot, Delhi/Chandigarh/Calcutta
5. All Officers at Hqrs.,
Chandigarh.

Sub: First amendment in Haryana Dairy Cooperative Staff Service Rules, 1988.

- - -

Dear Sir,

In accordance with the decision of the BOD of the HDDCI taken vide their Resolution No.1349/80/91 in its 80th meeting held on 2.5.1991 the existing rule 13.2(iv & v) is hereby substituted by the following sub rule :-

"Managing Director would be the appointing authority of posts in Group A, B, C & D except posts mentioned at (i), (ii) and (iii) above. Below Rule 13.1(a) and above 13.1(b), the following shall be added :-

13.1(a) Functions of the Personnel Committee.

- a) Review of staff strength, organisational charts, creation of new posts & abolition of posts.
- b) Selection of officers on direct recruitment on posts under Group A & B but where the Board makes a request to any outside agency such as the NDDB to select personnel, there will be no need to get such selection approved from the Personnel Committee. However, the Personnel Committee may further constitute a Committee which may have outside

... 2 *lys*

- : 2 : -

Experts for helping in making the selection of suitable officers.

- c) To recommend giving of productivity linked incentive to the employees.
- d) To recommend award of major punishment to officers of Group A & B.

The amendment of Rules would be effective from 2.5.9 i.e. from the date of decision by the Board. A copy of this letter may be displayed on the Notice Board for information of all employees.

Yours faithfully,

G Sharma

for Chief Admn. Officer,
Managing Director

Endstt. No. Estt/Mgr(P&A)/Ser.Rules/91/2137-46 dt: 21-

A copy is forwarded for information and necessary action to :-

1. All Chief Executive Officers, Milk Unions in the State of Haryana (3 copies each)
2. All Dealing Assistants in Admn, Estt. and Legal branches at H.O. Chandigarh
3. NOTICE BOARD.

G Sharma

for Chief Admn. Officer,
Managing Director

-136-

THE HARYANA DAIRY DEVELOPMENT CO-OPERATIVE FEDERATION LIMITED
D.C.O. NOS. 127-28, STATES 17-C, CHANDIGARH

Ref. No. Estt/A-D. 1/101/94/1187-1188 Dt. 17-11-84

1. All the Chief Executive Officers,
Milk Unions in the State
2. The General Manager,
Milk Plants;
3. Incharge,
Milk Plant, Bhiwani
4. Manager, S.B.T.C.,
Rohtak;
5. All Incharge,
Sale Depots under the Federation
6. All Officers at Hqrs. of
HDDCF, Chandigarh.

Sub: 2nd amendment in Haryana Dairy Co-operative
Staff Service Rules, 1976.

Dear Sir,

In accordance with the decision of the BOD of the HDDCF taken vide their resolution no. 1518/97/74 in its 97th meeting held on 29.9.94, the existing rule 42 IV(e) Sub Para II is hereby amended and substituted by the following :

42. IV(e) Sub Para-II :

"Maternity leave including miscarriage and abortion shall not be admissible to female employees having more than two living children. In such cases, leave of the kind due or extra ordinary leave will be allowed."

The above amendment of rules would be effective from 29.9.94 i.e. the date of meeting of the Board. A copy of this letter may be displayed on the notice board for information of all employees.

Yours faithfully,

H.V.-A
Chief Adm. Officer
for Managing Director.

C.C:-

1. All dealing Assistants, Adm. & Legal branch,
HDDCF.
2. Notice Board.

Ref. No. Astt/E-5/95, 7196-7206 Dated: 17-2-95

To

1. All the Chief Executive Officers, Milk Unions in the State of Haryana.
2. The General Manager, Milk Plant, Rohtak.
3. Incharge, Milk Plant, Shiwani.
4. Manager, S. S. T. C., Rohtak.
5. All Incharge, Sales Depots under the Federation
6. All Officers at Hqrs. of HDDCF, Chandigarh.

Sub: Third amendment of the Haryana Dairy Cooperative's Staff Service Rules, 1986 : Rule No. 42.4(c) (ii) regarding Half Pay Leave.

Dear Sir,

In accordance with the decision of the B.O.D. of the HDDCF taken vide their resolution No. 1531/95/95 in its 99th meeting held on 16.1.95, the existing Rule No. 42.4(c), (ii) of the Haryana Dairy Co-operative Staff Service Rules, 1986 is hereby amended and substituted by the following :

42.4(c) (ii)

"Half pay leave may be granted to an employee on medical grounds as well as on private affairs. Half Pay Leave may be computed on medical certificate upto a maximum of 180 days and twice the amount of such leave shall be debited against half pay leave due."

The above amendment of rules would be effective from 16-1-95 i.e. the date of meeting of the Board. A copy of this letter may be displayed on the notice Board for information of all employees.

Yours faithfully,

A. V. S.
Chief Adm. Officer
Managing Director.

CC:-

1) Manager (A.F.), Hqrs. w.r.t. his endst. No. 6409 dt. 30-1-95.

- ii) All dealing Assistants, Adm. & Legal Br., HDDCF.
- iii) Notice Board.

Agenda Item no. 18/139/05

To consider and approve the revised organizational charts of Milk Unions and Federation and amendment in service rules

Objectives of Restructuring

- i. Changed/Competitive Business Environment.
- ii. Reduction of Categories by Merging.
- iii. Avoid Stagnation by providing more Promotional avenues.
- iv. Right Sizing of the Manpower.
- v. Improvement in Qualifications at the entry level.
- vi. Creation of New Posts to cope with New Business Operations/ Technologies.
- vii. Re-nomenclature for Uniformity across cadres.
- viii. Identification of diminishing/ dying Cadre
- ix. Compliance of Govt. Directions.

In 1988 Organizational charts and then Service Rules were framed. The staff strength was fixed keeping in view workload of Milk Plant, Milk Unions and other offices at that time. The other major assumption was that the Federation would run Milk Plants.

In 1991 Milk Plants were leased out to Milk Unions. Bulk of the staff working with Federation got transferred to Milk Unions on notional deputation and they are continuing like that. The organizational Charts were not changed. The Milk Unions didn't create any posts for running Milk Plants. Federation established several Sale Depots and Sale Booths but no additional posts were got created. No staff has been employed ever since.

Over a period of time a need has been felt to revise the organizational charts of Milk Unions and Federation to cater to the demands of the Organization especially under the circumstances that the work load has increased many a times since 1987-88. The annual turn over has reached Rs. 400 crore from Rs. 26.52 crores during 1987-88. Liquid Milk Sale has reached 5,50,000 litres per day including Mother Dairy sale from 80,000 litres per day in 1987-88. Many new products have been added. Since no new recruitment has been made many key functionaries especially in Technical Section have got retired. There are vacancies on almost all Technical posts in all the Milk Plants. Even the posts of Quality Control Officers are vacant. In the present day competition where high level of efficiency is required Organizations are required to be equipped sufficiently with right kind of manpower. At the same time there are posts in class-III & IV categories, which are excess to the needs of the Organization. Virtual stagnation and no promotion since 17 years has adversely affected the motivation of employees. Most of the key functionaries have reached at the end of their pay scales and are feeling frustrated. Many are trying to go out of the Organization to seek better avenues.

The above situation called for an exercise of right sizing of the staff. Before this exercise could be initiated and completed a case was moved to Haryana Bureau of Public Enterprises to seek their concurrence. A meeting in this regard was held on 5-12-03 under the chairmanship of Chairman, Haryana Bureau of Public Enterprise. The following three decisions were taken by the Bureau: -

- i. Milk Unions will absorb the staff of Federation working with them after seeking the approval of their BODs and M.D., HDDCF exercising the powers of RCS.
- ii. Milk Unions should not come in the purview of HBPE.
- iii. The Federation and Milk Unions should complete transfer/absorption by 28-2-04 and thereafter the Federation should formulate the restructuring proposal pertaining to other categories of post and send it to HBPE for consideration.

To give effect to absorption of employees of Federation in Milk Unions, it was necessary to frame revised organizational charts of Milk Unions & Federation. The exercise has been completed with the concurrence of representatives of Milk Unions.

Provision with regard to revision of posts in Staff Service Rules (as per clause 3.5) adopted by Milk Unions and Federation is as under: -

"The staff strength shall periodically be reviewed by the Board of the Federation and the concerned Union and the concerned Board shall be competent to increase or decrease the strength. Provided that approval of Board of the Federation shall be required to increase the staff strength of a Union")

The chief characteristics of the same are given as under: -

Three posts of Chief General Manager in the pay scale of Rs.18400-22400 will be created at the Federation level.

Unlike other sister organizations the General Manager/Chief Executive Officer of the Milk Union in our organization is comparatively placed in a lower payscale. Since General Manager is working at the helm of the affairs of the Milk Union it is proposed that the post of GM be upgraded from the existing pay scale of Rs.10000-15200 to the pay scale of Rs.13500-17250

Assistant General Manager(Grade 8000-13500) & above are on common cadre. These posts will appear in the organizational charts of Milk Unions and Federation both. Recruitment of these posts will be made by Federation and deputed to Milk Unions.

To ensure better prospects and to avoid frustration/stagnation, persons/incumbents of the post will be elevated to the higher post after certain period of regular satisfactory service in the pay scale subject to availability of vacant post.

Out of the posts of General Manager(GM) in the payscale of Rs. 13500-17250 and Chief General Manager in the payscale of Rs. 18400-22400 only one post will be filled up at a time. If GM is promoted to the post of Chief General Manager then the post of GM from where he is promoted will remain vacant.

Out of three posts of General Manager (Semen Bank) in the payscale of Rs. 13500-17250, Dy.GM (semen Bank) in the payscale of Rs. 10000-15200 and AGM in the payscale of Rs.8000-13500 only one post will be filled up

at a time. If AGM is promoted to the post of DGM(Semen bank) then the post of AGM from where he is promoted will remain vacant. If DGM(Semen Bank) is promoted to the post of GM(Semen Bank) then the post of DGM(Semen bank) from where he is promoted will remain vacant

Out of the posts of AGM in the pay scale of Rs.8000-13500 and DGM in the pay scale of Rs.10000-15200 only one post will be filled up at a time. If AGM is promoted to the post of DGM then the post of AGM from where he is promoted will remain vacant.

Various categories of posts with pay scale 10000-13900 and 10000-15200 are proposed to be merged and will be designated as Dy. General Manager in the pay scale of Rs. 10000-15200. However the incumbent of the posts who were having a pay scale of 10000-15200 prior to the merger of pay scales will be considered first for promotion to the higher post. In case there is no person in the pay scale of Rs.10000-15200 in a particular category of post then the person with a pay scale of Rs. 10000-13900 will be considered for promotion to the higher post.

Similarly categories of posts with pay scale of Rs. 6500-10500 and 6500-9900 are also proposed to be merged and will be designated as Manager in the pay scale of Rs. 6500-10500. Further the incumbents of the post who were having a pay scale of Rs.6500-10500 prior to the merger of the pay scale will be considered first for the promotion to the higher post. In case there is no person in the pay scale of Rs.6500-10500 in a particular category of post then the person with a pay scale of Rs. 6500-9900 will be considered for promotion to the higher post

Further categories of posts with pay scale of Rs.5000-7850 and Rs.5000-7100 are also proposed to be merged and will be designated as Executive Assistant. However the incumbents of the post who were having a pay scale of Rs.5000-7850 prior to the merger of the pay scale will be considered first for the promotion to the higher post. In case there is no person in the pay scale of Rs.5000-7850 in a particular category of post then the person with a pay scale of Rs. 5000-7100 will be considered for promotion to the higher post.

As and when a new milk chilling centre will be set up the posts for these chilling centres will be created on the pattern recommended for other chilling centres separately.

As & when a new Sale Depot/s will be opened staff will be positioned in the Sale Depot/s as under:

In the Sale Depot with a annual turnover less than Rs 5.00 crores one post of AM (Mktg), one Executive Asstt.(Mktg) and one Clerk will be provided. In the Sale Depot with a annual turnover of more than Rs. 5.00 crores one post of Mgr(Mktg), one Executive Asstt (Mktg) and one clerk will be provided.

A Civil Engg. Cell will be created at the Federation level. The requirement of the post of JE(civil) will be met out of the staff to be provided at the Federation level. Designation

of the different posts in Civil Engg. Cell have been kept at par with the ones existing in Govt. Deptt. It will facilitate to borrow the services of an employee holding a similar post in the Govt. Departments.

One Executive Asstt. (Proc.) will be posted against 25 functional societies (average for the year). After increase of every 25 functional societies one additional post of Exe Asstt. (Proc) be created.

One AM(Proc) will be posted against 150 societies (average for the year).

One Mgr(Proc.) will be posted against 400 societies(average for the year)

Jobs given /to be given on contract basis

- Security
- Crate washing/Crate Loading/Unloading
- Operation of Pouch filling Machines
- Can washing
- Firing of rice husk in boilers.
- Packing of table Butter/Powder/Ghee
- and transfer of the products to stores.
- Loading of Milk Products in trucks
- Sweeping and sewerage cleaning
- Gardening/maintenance of lawns etc.
- E.T.P. Operation
- Sorting of pouches.
- Ghee filling, pouching and packing
- Resource persons to be deployed to strengthen the field activity for milk procurement enhancement

If the union intends to get any other job done on contract basis, other than the jobs listed above, they may do so after seeking the approval from the BODs of the Milk Union. Further some jobs which have been included in the Union charts may also be got done through contractor subject to approval of BODs of concerned Union.

Posts denoted ** in the organization charts means 100% under diminishing cadre.

Post denoted* in the organization charts means under diminishing cadre.

These posts will continue to exist till their retirement. There is no proposal for their retrenchment.

The recruitment of new posts will be made in a phased manner in proportion to retired employees as to have the marginal financial burden on the Milk Unions/Federation.

There is some inconsistency in the designations of the various categories of posts. For example Dy. Manager(Prod.) is in the payscale of Rs. 8000-13500 where as Manager(Mktg) is in the payscale of Rs 6500-10500. To bring in uniformity in the designations the organizational charts have been revised accordingly. Now Extension & Milk procurement Asstt.(EMPA) in the payscale of Rs.5000-7850 will be designated as

Exe.Asstt.(Proc.).Similarly Asstt. Dairy Supervisor in the similar payscale of Rs 5000-7850 will be designated as Exe.Asstt.(Prod.).On the same analogy the designation of the different categories of posts will be changed.

The qualifications and mode of recruitment of various categories of posts in the service of concerned Milk Union and of the Federation have been shown in Annexure A and Annexure B respectively.

After Board of Directors of Federation approves the revised organizational charts, Milk Unions will get the same approved from their respective Board of Directors. As a first step Milk Unions will absorb the Federation's staff and the staff posted from the cadre of other Unions on the terms and conditions given as under: -

1. The services of the employees even on deputation would not be interrupted by this absorption and the emoluments/benefits/pay scales, which the employees are presently enjoying, would be protected.
2. The terms and conditions of the service including retiral benefits would not be in any way less favourable to employees than applicable to them immediately before the absorption and these would be protected.
3. In the event of the retrenchment the Milk Union would be liable to pay to them compensation on the basis that their services have been continuous and have not been interrupted by their absorption.
4. Interse seniority of the employees of the Federation/other Milk Union to be absorbed in the Milk Union will be maintained by the respective Milk Union. The seniority in the category of their post in the milk union will be counted from the date of their joining on the present post/scale in the organization i.e. Federation/corporation/Milk Union.
5. They will be governed by Haryana Dairy Coop. Staff service rules 1988 as amended from time to time and applicable to Milk Unions.
6. The Federation will discharge its liabilities towards retiral benefits payable to employees for the period they have rendered services with the Federation. Therefore, the Unions have agreed that entire retiral benefits shall be paid to the employees by the respective Milk Union at the retirement of each employee.
7. The employees will be absorbed in the Milk Union where they are working presently. They will also have an option to seek absorption in their parent Milk Union/Federation from where they have been sent on deputation to other Milk Unions. Other than this the employees cannot seek absorption in other Milk Union.

Federation will send the restructuring proposal pertaining to their posts including of common cadre to HBPE for consideration and approval

Matter is placed before the Board of Directors for consideration and approval of the following decisions:-

The revised organizational charts of Milk Unions and Federation along with revised qualifications and mode of recruitment are approved. The service rules are amended to that extent. These will come into force from the date these are approved by BODs of respective Milk Unions and in case of Federation by the HBPE.

The staff of Federation be absorbed by Milk Unions as per terms and conditions from 1 to 7 given above.

STAFF STRENGTH		
	Sanctioned Posts	Filled Posts
Class-I	59	17
Class-II	64	37
Class-III	942	648 502
Class-IV	504	480 **
Total	1569	1182

RETIRING EMPLOYEES					
YEAR	CLASS				NO. OF EMPLOYEES
	I	II	III	IV	
2005-06	4	1	25	7	37
2006-07	1	1	29	5	36
2007-08	3	5	42	14	64
2008-09	3	9	49	10	71
2009-10	3	3	59	11	76
2010-11	-	2	53	7	62
2011-12	-	-	51	25	76
2012-13	1	7	79	17	104
2013-14	-	2	60	27	89
Total	15	30	447	123	615

DESIGNATION CHANGED ACROSS THE ORGANIZATION		
Sr.No.	Pay Scale	Designation
1	18400-22400	Chief General Manager
2	13500-17250	General Manager
3	10000-15200 10000-13900	Dy. General Manager
4	8000-13500	Asstt. General Manager
5	6500-10500 6500-9900	Manager
6	5500-9000	Asstt. Manager
7	5000-7850 5000-7100	Executive Assistant

→ 18400-500-22400
(Page 77 of S-7)

→ 13500-375-17250
(Page 73 of S-7)

10,000-325-15200
10000-325-13900
page 70 of S-7 + Page 74

DIVISION WISE DETAIL OF THE POSTS IN MILK UNIONS & FED.

Division	Sanctioned Posts	Filled up Posts	Required	Diminishing Cadre	Addl. Posts required
	1	2	3= (2-4+5)	4	5
A) Milk Unions					
CEO/GM	6	1	6	0	5
Procurement & Input	242	231	197	71	37
Prod & Engg.	650	494	329	288	123
Quality Control	93	58	96	23	61
Accounts & Finance	81	34	48	6	20
Admn. Store & Purchase	302	241	131	160	50
Plng. MIS & Systems	8	7	16	4	13
Marketing	14	14	60	1	47
Total	1396	1080	883	553	356
B) Federation	173	102	155*	51	104
Grand Total(A+B)	1569	1182	1038	604	460
*Includes 67 common cadre posts and 5 posts of JE(Civil) to be created in Milk Unions/Federation					

Union wise details of posts sanctioned,existing/recommended staff strength,posts under Diminishing Cadre and Additional posts required

	Posts Sanctioned						Existing							
	Ambala	Hsr-Jind	Rohtak	Bgarh	Sirsa	Krk	Total	Ambala	Hsr-Jind	Rohtak	Bgarh	Sirsa	Krk	Total
CEO/GM	1	1	1	1	1	1	6	0	1	0	0	0	0	1
Procurement & Input	50	52	29	13	36	62	242	35	48	53	42	30	23	231
Production & Engineering	110	162	129	121	93	35	650	141	123	109	77	30	14	494
Quality Control	14	27	15	19	12	6	93	12	14	14	10	6	2	58
Accounts	13	20	14	14	10	10	81	9	5	7	5	5	3	34
Administration, Stores & Purchase	57	94	43	57	24	27	302	47	64	48	46	20	16	241
Plng, MIS & Systems	1	2	1	1	1	2	8	1	1	1	1	0	2	7
Mktg.	3	3	1	4	3	0	14	3	5	2	4	0	0	14
Total	249	361	233	230	180	143	1396	248	261	234	184	93	60	1080

	Required						Diminishing Cadre						Addl. Posts required									
	Ambala	Hsr-Jind	Rohtak	Bgarh	Sirsa	Krk	Total	Ambala	Hsr-Jind	Rohtak	Bgarh	Sirsa	Krk	Total	Ambala	Hsr-Jind	Rohtak	Bgarh	Sirsa	Krk	Total	
CEO/GM	1	1	1	1	1	1	6	0	0	0	0	0	0	0	0	0	1	1	1	1	1	5
Procurement & Input	30	35	51	32	27	22	197	9	15	18	18	8	3	71	4	2	16	8	5	2	37	
Production & Engineering	64	66	73	63	55	8	329	96	77	65	37	2	11	288	19	20	29	23	27	5	123	
Quality Control	19	17	19	18	18	5	96	5	4	8	3	1	1	23	13	7	13	11	13	4	61	
Accounts	9	9	9	9	8	4	48	3	0	2	0	0	0	1	6	3	4	4	4	2	23	
Administration, Stores & Purchase	23	25	26	25	22	10	131	32	45	34	31	6	12	160	8	6	12	10	8	6	52	
Plng, MIS & Systems	3	3	3	3	3	1	16	0	0	0	0	0	2	4	2	2	2	3	3	1	12	
Mktg.	17	8	13	11	7	4	60	0	1	0	0	0	0	1	14	4	11	7	7	4	47	
Total	166	164	195	162	141	55	883	146	142	127	89	19	30	553	67	67	88	67	67	25	356	

Details of posts sanctioned,existing/recommended staff strength,posts under Diminishing Cadre and Additional posts required in the Federation.						
Posts sanctioned	Existing	Required			Diminishing cadre	Addl. posts reqd.
		To be sent on deputation to Milk unions	Federation	Total		
Managing Director	1	1	1	1		
Chief Admn. Officer	1	1	1	1		
Procurement,Cooperation& Input	4	2	11	14	2	14
Production,Quality control,Engineering and transport	20	13	41	19	60	1
Accounts & Finance	18	10	10	20	3	13
Administration,Stores & Purchase	86	48	0	25	28	5
Plng,MIS & Systems	4	2	5	8	13	0
Mktg.	13	13	5	8	13	8
Semen Bank cum Training Centre,Rohtak	26	12	0	8	8	9
Total	173	102	72	83	155	51
						104

RECOMMENDED ORGANISATIONAL STRUCTURE OF MILK CHILLING CENTRES ATTACHED WITH MILK UNION AMBALA

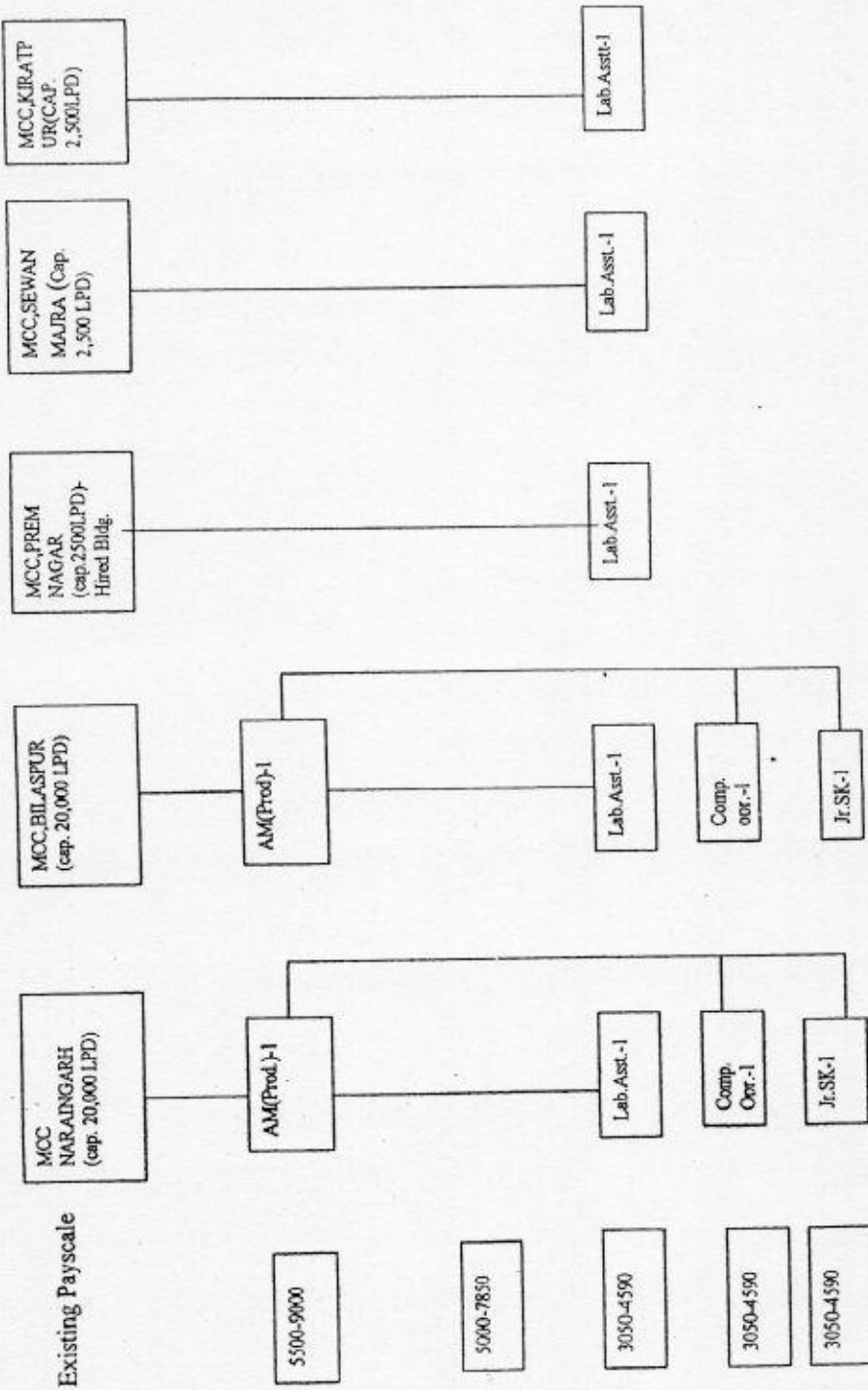

Figs. given above denotes requirement

Note: I) On page-1 figs. in parenthesis () denotes existing staff strength and figs. parallel to it indicates requirement of staff.
 II) DGM stands for Deputy General Manager, AGM- Asstt. General Manager, Mgr.-Manager, AM-Asstt. Manager
 EA-Executive Asstt.

RECOMMENDED ORGANISATIONAL STRUCTURE OF SALE DEPOTS ATTACHED TO MILK UNION AMBALA

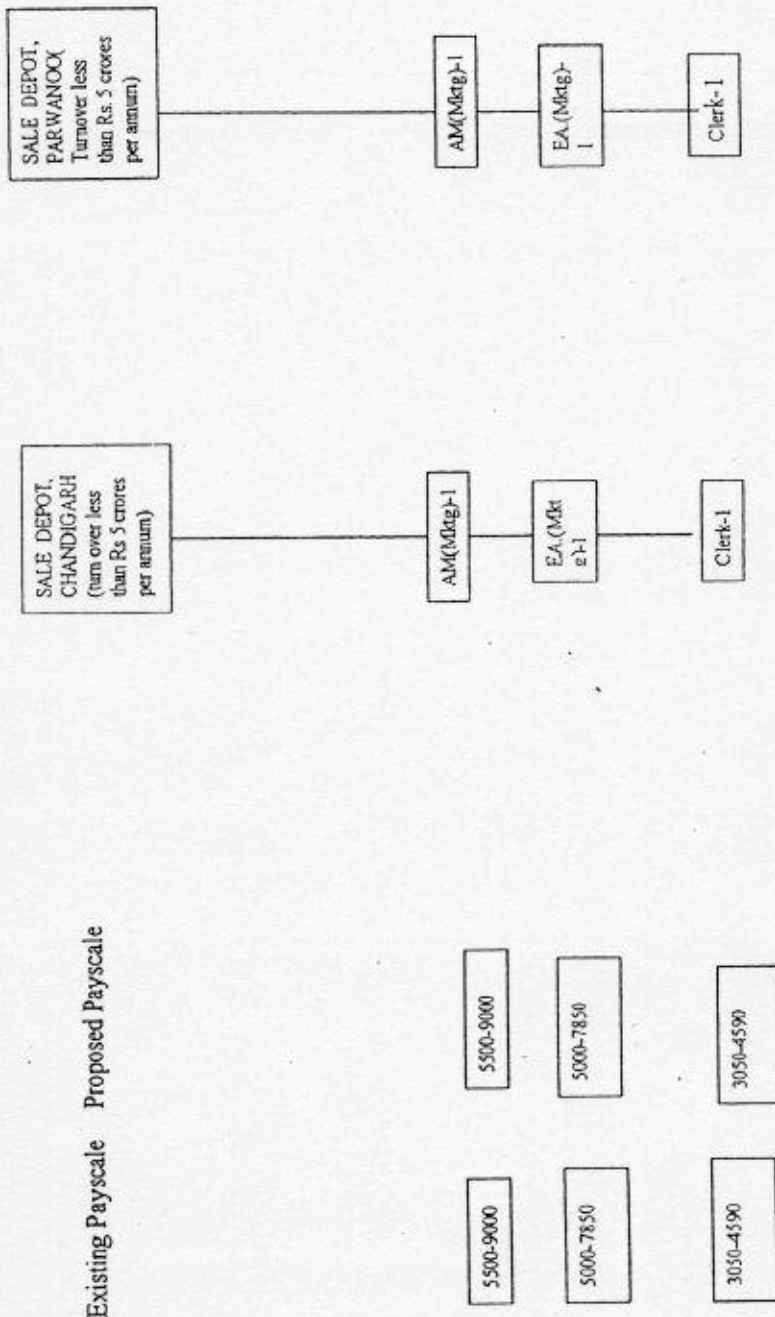

Figs. given above denotes requirement

MU AMBALA

Section	Posts Sanctioned	Existing	Required*	Dimin. cadre	Addl. Posts required
CEO	1	0	1	0	1
Procurement	50	35	30	9	4
Production & Engineering	110	141	64	96	19
Quality Control	14	12	19	6	13
Accounts	13	9	9	3	3
Admn; Store & Purchase	57	47	23	32	8
MIS	1	1	3		2
Marketing	3	3	17	0	14
Total	249	248	166	146	64

* includes the staff requirement of the Milk Chilling centres and Sale Depots

Jobs given /to be given on contract basis

- a) Security
- b) Crate washing/Crate Loading/Unloading
- c) Operation of Pouch filling Machines
- d) Can washing
- e) Firing of rice husk in boilers
- f) Loading of Milk Products in trucks
- g) Sweeping and sewerage cleaning
- h) Gardening/maintenance of lawns etc.
- i) E.T.P. Operation
- j) Sorting of pouches.
- k) Ghee filling, pouching and packing
- l) Resource persons to be deployed to strengthen the field activity for milk procurement enhancement
- m) If the union intends to get any other job done on contract basis, other than the jobs listed above, they may do so after seeking the approval from the BODs of the Milk Union.

MILK UNION, AMBALA

Other assumptions

1. Post of Steno in the payscale of Rs.5000-7850 has been clubbed with the post of EA (Admin).
2. One Executive Asstt. (Proc.) will be posted against 25 functional societies(average for the year).
After increase of every 25 functional socs. one additional post of EA (Proc) be created.
3. One AM(Proc) will be posted against 150 societies (average for the year)
4. One Mgr.(Proc.) will be posted against 400 societies(average for the year)
5. Promotion to the higher post from EA(proc) to the post of DGM(P&I) will be made when besides fulfilling functional societies criteria the milk procurement of the union in terms of average milk procurement/society/day is equivalent to the State average milk procurement/ society/day. The figure of the union will be compared with the average of the last 3 years of the State as a whole.
6. AGM & above on common cadre.
7. ** 100% posts under diminishing cadre.
* Posts under diminishing cadre.
8. No. of posts of driver will be according to the no. of vehicles plying in the union.
10. As and when a new milk chilling centre will be set up the posts for these chilling centres will be created on the pattern recommended for other chilling centres seperately.
11. A civil Engg. Cell will be created at the Federation level. The requirement of the post of JE(civil) will be met out of the staff to be provided at the Federation level.
12. As & when a new Sale Depot/s will be opened staff will be positioned in the Sale Depot/s as under:
In the Sale Depot with a annual turnover less than Rs 5.00 crores one post of AM(Mktg), one EA(mktg) and one Clerk will be provided. In the Sale Depot with a annual turnover of more than Rs. 5.00 crores one post of Mgr(Mktg), one EA(Mktg) and one clerk will be provided.
13. Post of FDO in the payscale of Rs. 6500-9900 will be designated as Manager(Inputs) and their requirement has been shown under the category of post Manager(Proc./Inputs)

MILK UNION, AMBALA

Career/Succession Planning

To ensure better prospects and to avoid frustration/stagnation, persons/incumbents of the post will be elevated to the higher post after certain period of regular satisfactory service in the pay scale.

However, out of the posts of AGM in the payscale of Rs. 8000-13500 and DGM in the payscale of Rs. 10000-15200 only one post will be filled up at a time. If AGM is promoted to the post of DGM, then the post of AGM from where he is promoted will remain vacant.



**RECOMMENDED ORGANISATIONAL STRUCTURE OF MILK UNION-HISAR-JIND
CHIEF EXECUTIVE OFFICER/GM**

10000-15200 Existing Pay scale
13500-17250 Proposed Payscale

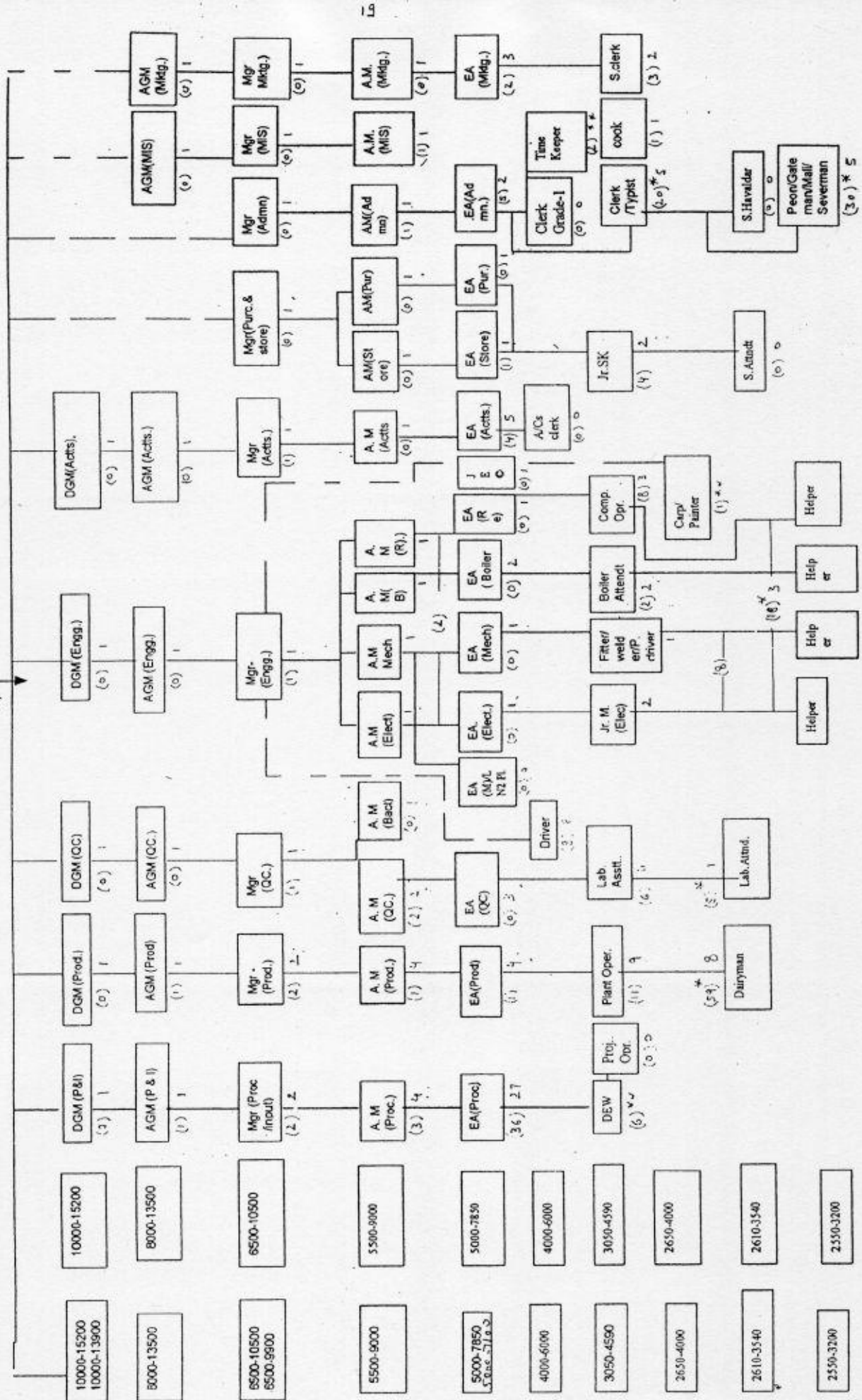

RECOMMENDED ORGANISATIONAL STRUCTURE OF MILK CHILLING CENTRES ATTACHED WITH MILK UNION HISAR-JIND

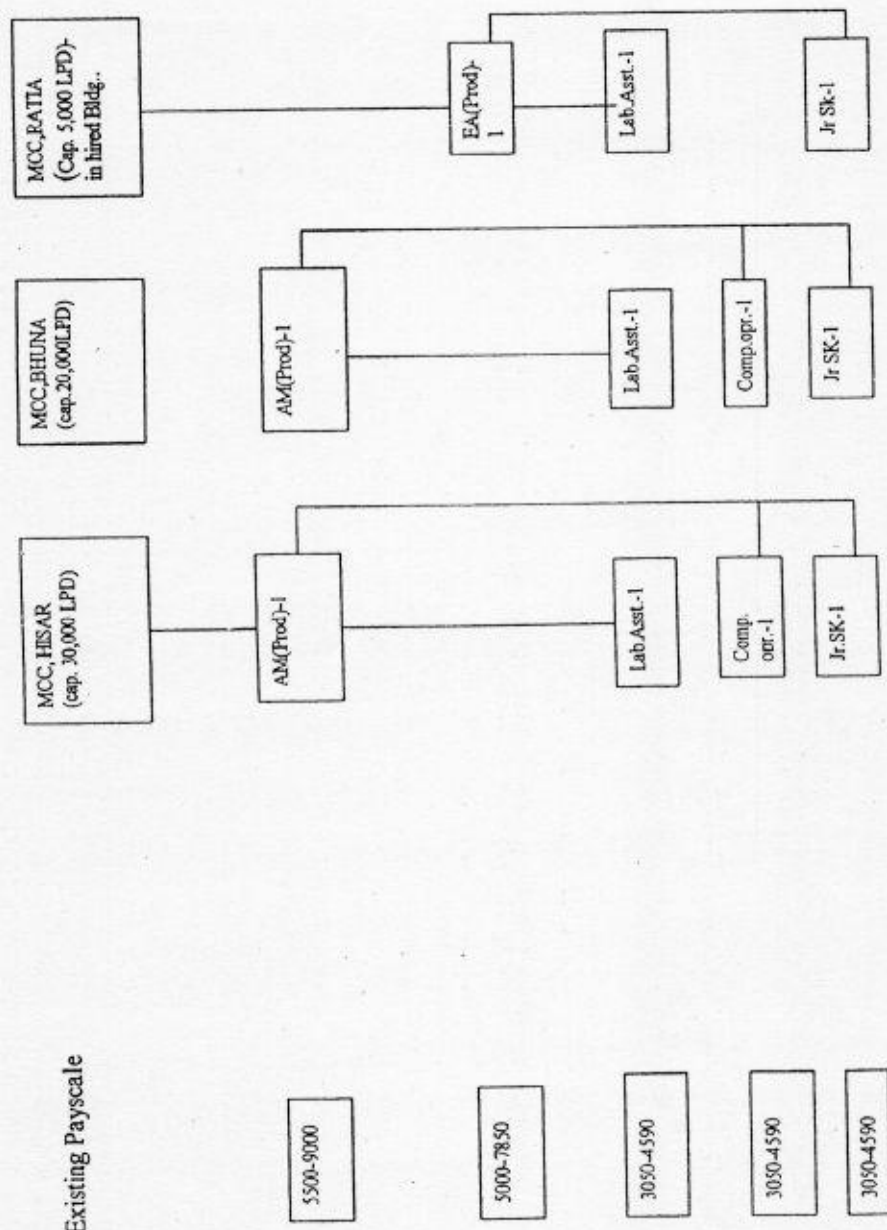

Figs. given above denotes requirement

Note: I) On page-1 figs. in parenthesis () denotes existing staff strength and figs. parallel to it indicates requirement of staff.
 II) DGM stands for Deputy General Manager, AGM- Asstt. General Manager, Mgr.- Manager, AM-Asstt. Manager EA-Executive Asstt.

MU HISAR-JIND

Section	Posts Sanctioned	Existing	Required*	Dimin. cadre	Addl. Posts required
CEO/GM	1	1	1	0	0
Procurement	52	48	35	15	2
Production & Engineering	162	123	66	77	20
Quality Control	27	14	17	4	7
Accounts	20	5	9	0	4
Admn; Store & Purchase	94	64	25	45	6
MIS	2	1	3	0	2
Marketing	3	5	8	1	4
Total	361	261	164	142	45

* includes the staff requirement of the Milk Chilling centres

Jobs given /to be given on contract basis

- a) Security
- b) Crate washing/Crate Loading/Unloading
- c) Operation of Pouch filling Machines
- d) Can washing
- e) Firing of Rice Husk, Coal in boilers
- f) Packing of Powder/Ghee and transfer Of the products to Stores
- g) Loading of Milk Products in trucks
- h) Sweeping and sewerage cleaning
- i) Gardening/maintenance of lawns etc.
- j) Sorting of pouches.
- k) Ghee filling, pouching and packing
- l) E.T.P. Operation
- m) Resource persons to be deployed to strengthen the field activity for milk procurement enhancement
- n) If the union intends to get any other job done on contract basis, other than the jobs listed above, they may do so after seeking the approval from the BODs of the Milk Union.

Other assumptions

1. Post of Steno in the payscale of Rs.5000-7850 has been clubbed with the post of EA.(Admn).
2. One Executive Asstt. (Proc.) will be posted against 25 functional societies(average for the year).
After increase of every 25 functional socs. one additional post of EA (Proc) be created.
3. One AM(Proc) will be posted against 150 societies (average for the year)
4. One Mgr.(Proc.) will be posted against 400 societies(average for the year)
5. Promotion to the higher post from EA(proc) to the post of DGM(P&I) will be made when besides fulfilling functional societies criteria the milk procurement of the union in terms of average milk procurement/society/day is equivalent to the State average milk procurement/ society/day. The figure of the union will be compared with the average of the last 3 years of the State as a whole.
6. AGM & above on common cadre.
7. ** 100% posts under diminishing cadre.
* Posts under diminishing cadre.
8. No. of posts of driver will be according to the no. of vehicles plying in the union.
10. As and when a new milk chilling centre will be set up the posts for these chilling centres will be created on the pattern recommended for other chilling centres separately.
11. A civil Engg. Cell will be created at the Federation level. The requirement of the post of JE(civil) will be met out of the staff to be provided at the Federation level.
12. As & when a new Sale Depot/s will be opened staff will be positioned in the Sale Depot/s as under:
In the Sale Depot with a annual turnover less than Rs 5.00 crores one post of AM(Mktg),one EA(Mktg) and one Clerk will be provided. In the Sale Depot with a annual turnover of more than Rs. 5.00 crores one post of Mgr(Mktg),one EA(Mktg) and one clerk will be provided.
13. Post of FDO in the payscale of Rs. 6500-9900 will be designated as Manager(Inputs) and their requirement has been shown under the category of post Manager(Proc./Inputs)

MILK UNION, HISAR-JIND

Career/Succession Planning

To ensure better prospects and to avoid frustration/stagnation, persons/incumbents of the post will be elevated to the higher post after certain period of regular satisfactory service in the pay scale.

However, out of the posts of AGM in the payscale of Rs.8000-13500 and DGM in the payscale of Rs.10000-15200 only one post will be filled up at a time. If AGM is promoted to the post of DGM, then the post of AGM from where he is promoted will remain vacant.

RECOMMENDED ORGANIZATION FOR U.S. MILITARY AND NAVAL
CHIEF EXECUTIVE OFFICER/GM

10000-15200 Existing Pay scale
 13500-17250 Proposed Payscale

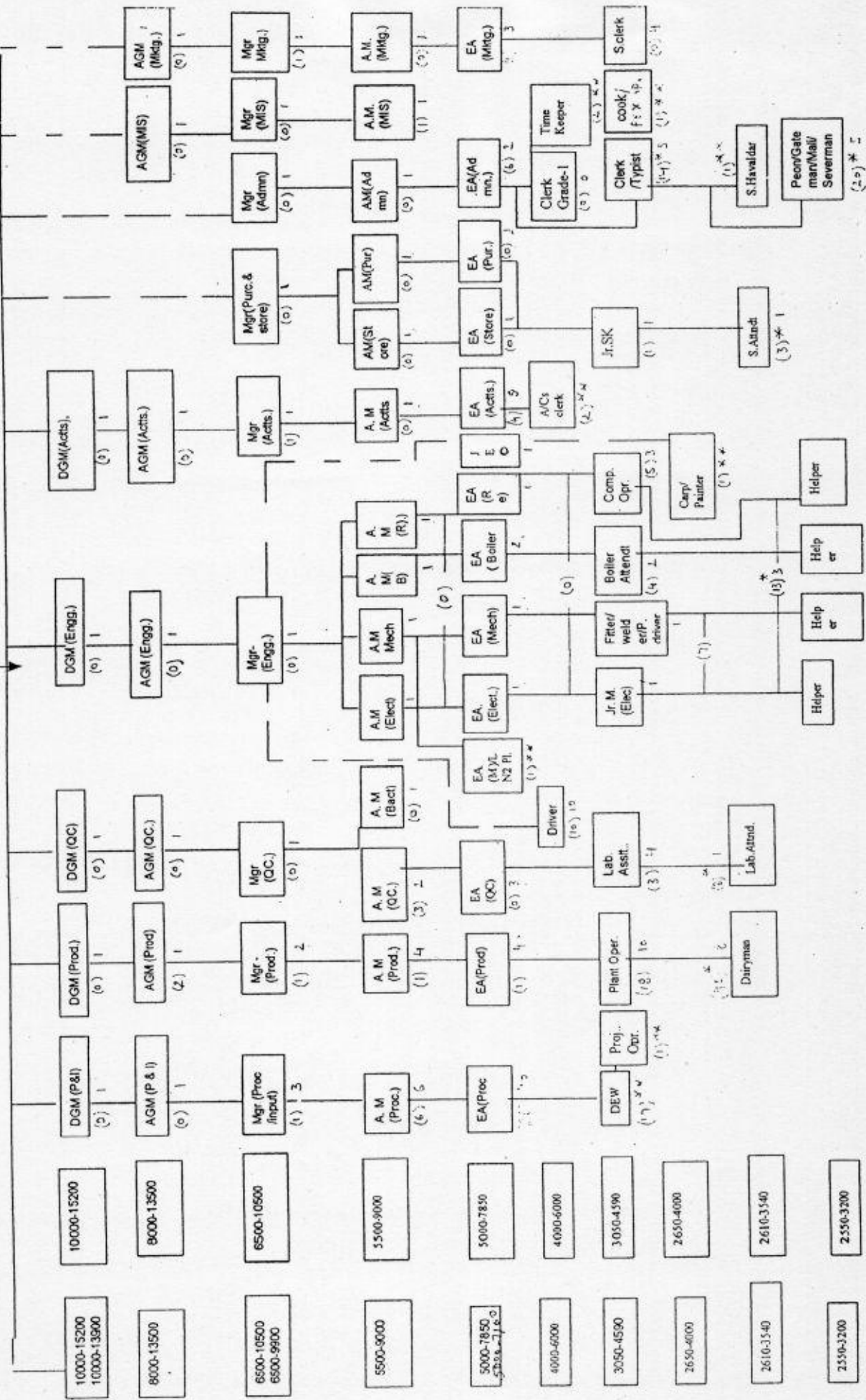

RECOMMENDED ORGANISATIONAL STRUCTURE OF MILK CHILLING CENTRES ATTACHED WITH MILK UNION ROHTAK

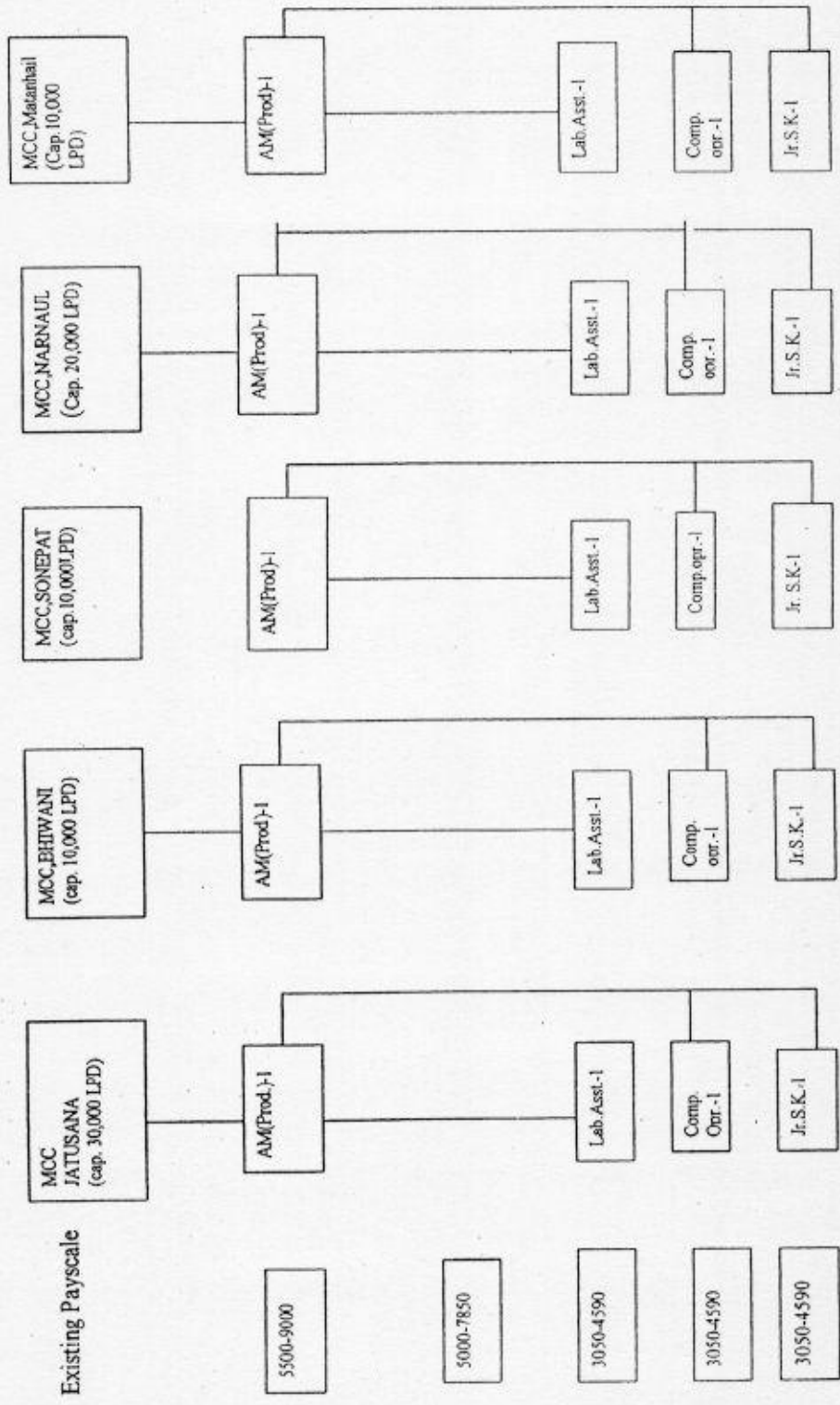

Figs. given above denotes requirement

Note:1 -On page-1 figs. in parenthesis () denotes existing staff strength and figs. parallel to it indicates requirement of staff.
 II-DGM stands for Deputy General Manager, AGM- Asstt. General Manager, Mgr.-Manager, AM-Asstt. Manager EA-Executive Asstt.

RECOMMENDED ORGANISATIONAL STRUCTURE OF SALE DEPOT ATTACHED TO MILK UNION, ROHTAK

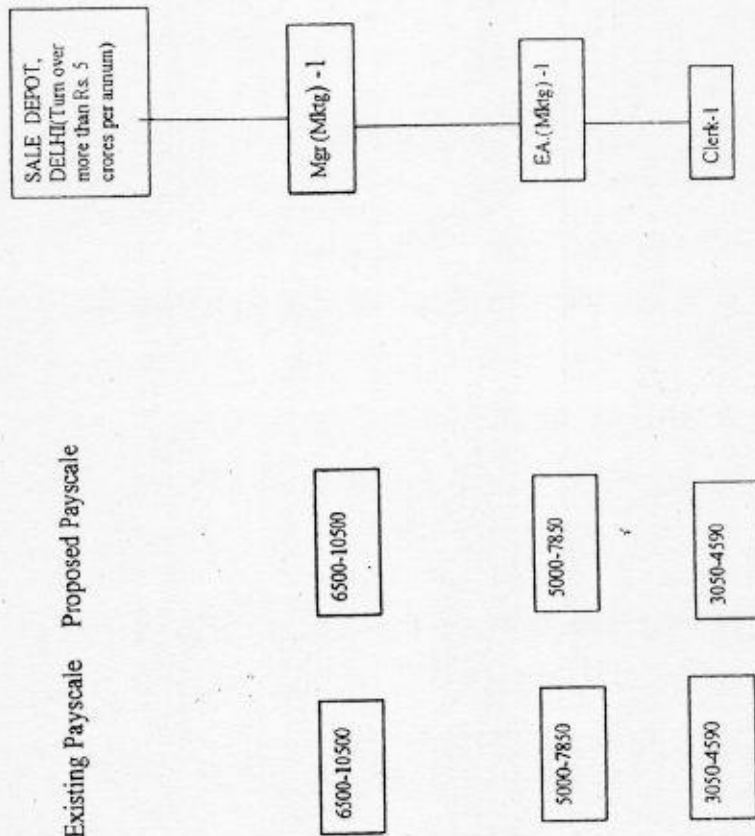

Figs. given above denotes requirement

MUROHTAK

Section	Posts Sanctioned	Existing	Required*	Dimin. cadre	Addl. Posts required
CEO/GM	1	0	1	0	1
Procurement	29	53	51	18	16
Production & Engg.	129	109	73	65	29
Quality Control	15	14	19	8	13
Accounts	14	7	9	2	4
Admn., Store & Purchase	43	48	26	34	12
MIS	1	1	3	0	2
Marketing	1	2	13	0	11
Total	233	234	195	127	88

* includes the staff requirement of the Milk Chilling centres and Sale Depots

Jobs given /to be given on contract basis

- a) Security
- b) Crate washing/Crate Loading/Unloading
- c) Operation of Pouch filling Machines
- d) Can washing
- e) Firing of rice husk in boilers.
- f) Packing of table Butter/Powder/Ghee and transfer of the products to stores.
- g) Loading of Milk Products in trucks
- h) Sweeping and sewerage cleaning
- i) Gardening/maintenance of lawns etc.
- j) E.T.P. Operation
- k) Sorting of pouches.
- l) Ghee filling, pouching and packing
- m) Resource persons to be deployed to strengthen the field activity for milk procurement enhancement
- n) If the union intends to get any other job done on contract basis, other than the jobs listed above, they may do so after seeking the approval from the BODs of the Milk Union.

Other assumptions

1. Post of Steno in the payscale of Rs. 5000-7850 has been clubbed with the post of EA (Admn).
2. One Executive Assst. (Proc.) will be posted against 25 functional societies (average for the year). After increase of every 25 functional socs. one additional post of EA (Proc) be created.
3. One AM(Proc) will be posted against 150 societies (average for the year)
4. One Mgr. (Proc.) will be posted against 400 societies (average for the year)
5. Promotion to the higher post from EA(proc) to the post of DGM(P&I) will be made when besides fulfilling functional societies criteria the milk procurement of the union in terms of average milk procurement/society/day is equivalent to the State average milk procurement/ society/day. The figure of the union will be compared with the average of the last 3 years of the State as a whole.
6. AGM & above on common cadre.
7. ** 100% posts under diminishing cadre.
* Posts under diminishing cadre.
8. No. of posts of driver will be according to the no. of vehicles plying in the union.
10. As and when a new milk chilling centre will be set up the posts for these chilling centres will be created on the pattern recommended for other chilling centres separately.
11. A civil Engg. Cell will be created at the Federation level. The requirement of the post of JE(civil) will be met out of the staff to be provided at the Federation level.
12. As & when a new Sale Depot/s will be opened staff will be positioned in the Sale Depot/s as under:
In the Sale Depot with a annual turnover less than Rs 5.00 crores one post of AM(Mktg), one EA(Mktg) and one Clerk will be provided. In the Sale Depot with a annual turnover of more than Rs. 5.00 crores one post of Mgr(Mktg), one EA(Mktg) and one clerk will be provided.
13. Post of FDO in the payscale of Rs. 6500-9900 will be designated as Manager(Inputs) and their requirement has been shown under the category of post Manager(Proc./Inputs)

MILK UNION, ROHTAK

Career/Succession Planning

To ensure better prospects and to avoid frustration/stagnation, persons/incumbents of the post will be elevated to the higher post after certain period of regular satisfactory service in the pay scale.

However, out of the posts of AGM in the pay scale of Rs. 8000-13500 and DGM in the pay scale of Rs. 10000-15200 only one post will be filled up at a time. If AGM is promoted to the post of DGM, then the post of AGM from where he is promoted will remain vacant.

RECOMMENDED ORGANISATIONAL STRUCTURE OF MILK CHILLING CENTRES ATTACHED WITH MILK UNION BALLABGARH

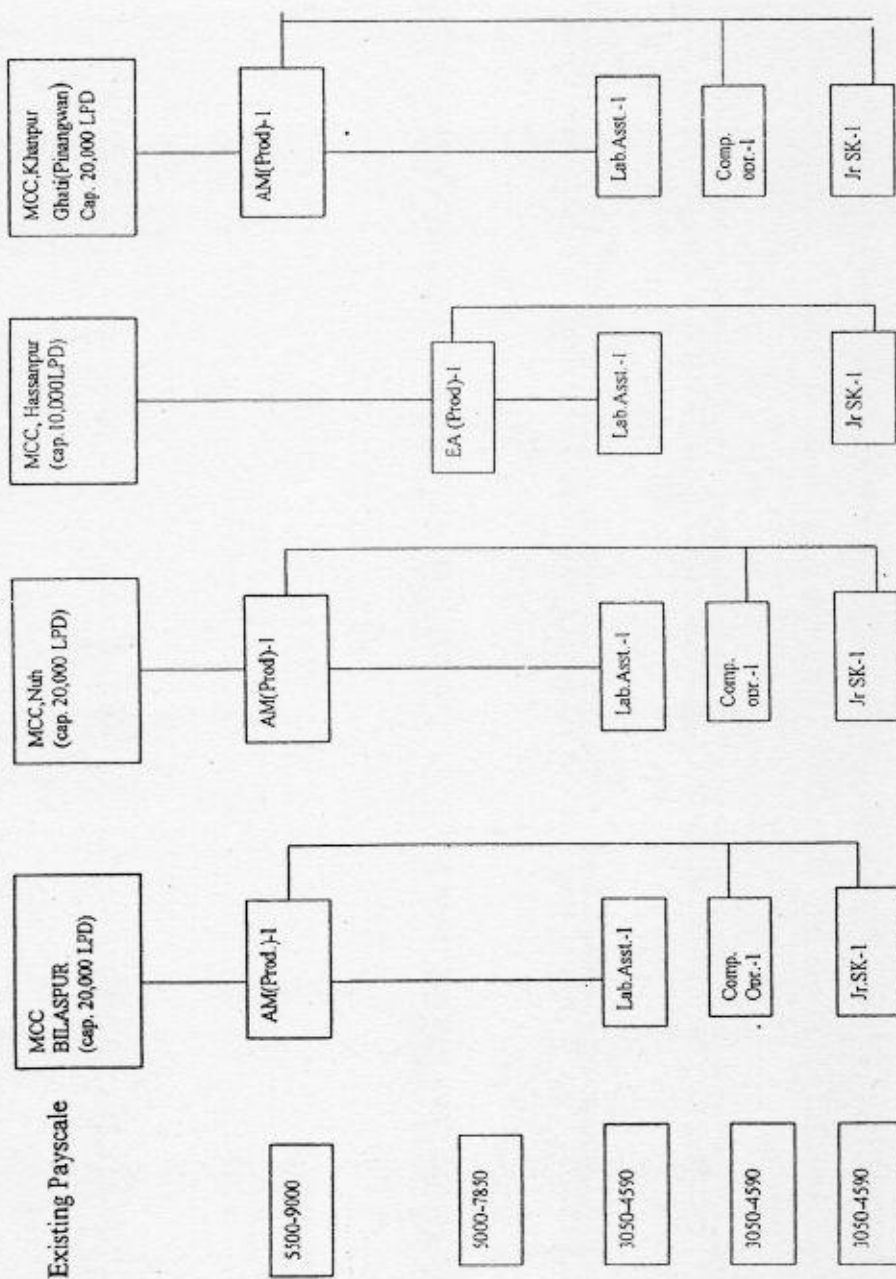

Figs. given above denotes requirement

Note: i) On page-1 figs. in parenthesis () denotes existing staff strength and figs. parallel to it indicates requirement of staff.
 ii) DGM stands for Deputy General Manager, AGM- Asstt. General Manager, Mgr.-Manager, AM-Asstt. Manager EA-Executive Asstt.

MU BALLABGARH

Section	Posts Sanctioned	Existing	Required*	Dimin. cadre	Addl. Posts required
CEO	1	0	1	0	1
Procurement	13	42	32	18	8
Production & Engineering	121	77	63	37	23
Quality Control	19	10	18	3	11
Accounts	14	5	9	0	4
Admn.; Store & Purchase	57	46	25	31	10
MIS	01	0	3	0	3
Marketing	04	4	11	0	7
Total	230	184	162	89	67

* includes the staff requirement of the Milk Chilling centres

Jobs given /to be given on contract basis

- a) Security
- b) Crate washing/Crate Loading/Unloading
- c) Operation of Pouch filling Machines
- d) Can washing
- e) Firing of Rice Husk, Coal in boilers
- f) Packing of Powder/Ghee and transfer Of the products to Stores
- g) Loading of Milk Products in trucks
- h) Sweeping and sewerage cleaning
- i) Gardening/maintenance of lawns etc.
- j) Sorting of pouches.
- k) Ghee filling, pouching and packing
- l) E.T.P. Operation
- m) Resource persons to be deployed to strengthen the field activity for milk procurement enhancement
- n) If the union intends to get any other job done on contract basis, other than the jobs listed above, they may do so after seeking the approval from the BODs of the Milk Union.

MILK UNION, BALLABGARH

Other assumptions

1. Post of Steno in the payscale of Rs.5000-7850 has been clubbed with the post of EA.(Admn).
2. One Executive Asstt. (Proc.) will be posted against 25 functional societies(average for the year). After increase of every 25 functional socs. one additional post of EA (Proc) be created.
3. One AM(Proc) will be posted against 150 societies (average for the year)
4. One Mgr.(Proc.) will be posted against 400 societies(average for the year)
5. Promotion to the higher post from EA(proc) to the post of DGM(P&I) will be made when besides fulfilling functional societies criteria the milk procurement of the union in terms of average milk procurement/society/day is equivalent to the State average milk procurement/ society/day. The figure of the union will be compared with the average of the last 3 years of the State as a whole.
6. AGM & above on common cadre.
7. ** 100% posts under diminishing cadre.
* Posts under diminishing cadre.
8. No. of posts of driver will be according to the no. of vehicles plying in the union.
10. As and when a new milk chilling centre will be set up the posts for these chilling centres will be created on the pattern recommended for other chilling centres seperately.
11. A civil Engg. Cell will be created at the Federation level. The requirement of the post of JE(civil) will be met out of the staff to be provided at the Federation level.
12. As & when a new Sale Depot/s will be opened staff will be positioned in the Sale Depot/s as under:
In the Sale Depot with a annual turnover less than Rs 5.00 crores one post of AM(Mktg), one EA(mktg) and one Clerk will be provided. In the Sale Depot with a annual turnover of more than Rs. 5.00 crores one post of Mgr(Mktg), one EA(Mktg) and one clerk will be provided.
13. Post of FDO in the payscale of Rs. 6500-9900 will be designated as Manager(Inputs) and their requirement has been shown under the category of post Manager(Proc./Inputs)

MILK UNION, BALLABGARH**Career/Succession Planning**

To ensure better prospects and to avoid frustration/stagnation, persons/incumbents of the post will be elevated to the higher post after certain period of regular satisfactory service in the pay scale.

However, out of the posts of AGM in the payscale of Rs. 8000-13500 and DGM in the payscale of Rs. 10000-15200 only one post will be filled up at a time. If AGM is promoted to the post of DGM, then the post of AGM from where he is promoted will remain vacant.



RELATIONSHIPS OF THE NATIONAL BUREAU OF MILITARY AFFAIRS
CHIEF EXECUTIVE OFFICER/IGM

10000-15200 Existing Pay scale
13500-17250 Proposed Payscale

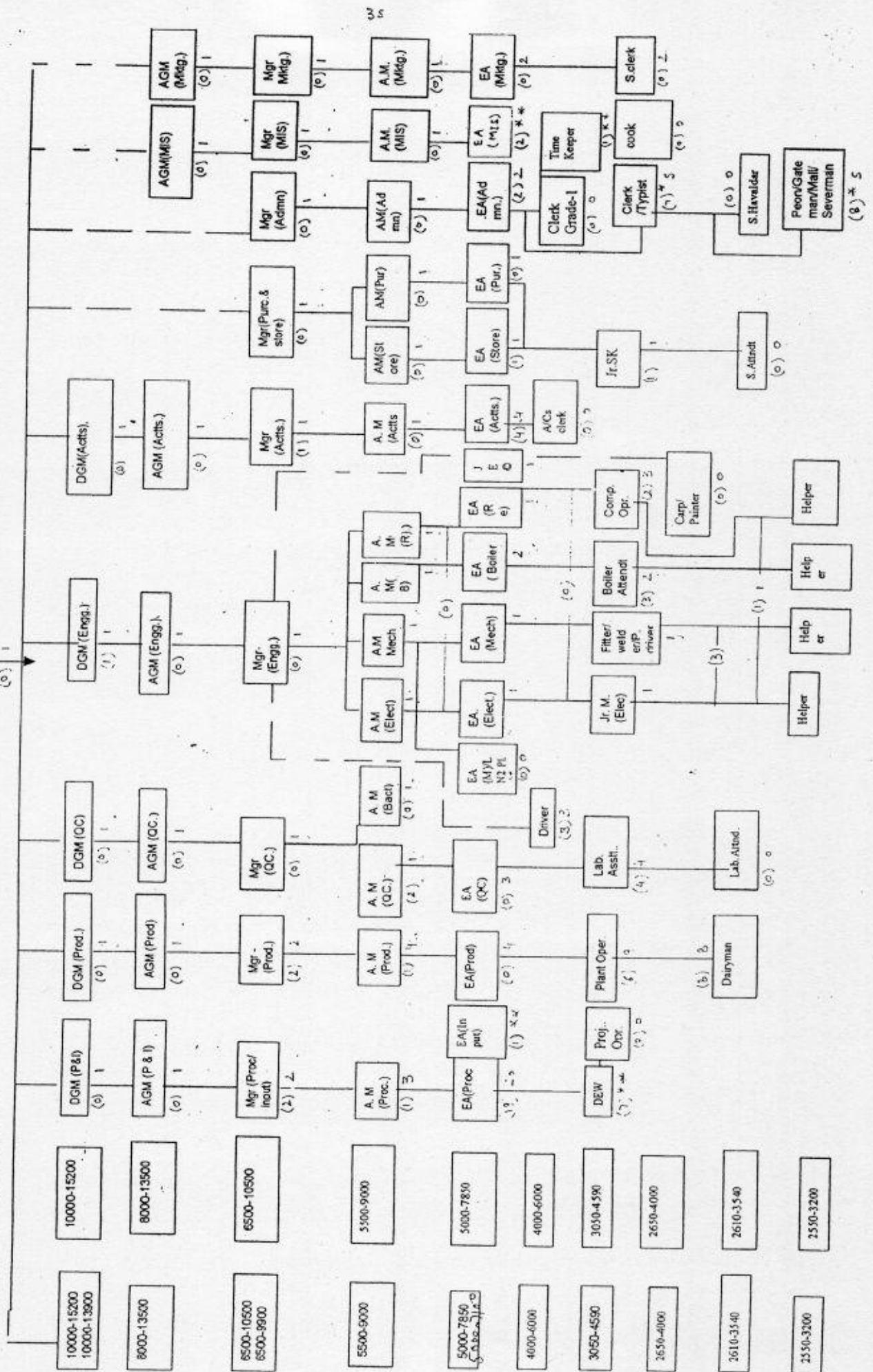

RECOMMENDED ORGANISATIONAL STRUCTURE OF MILK CHILLING CENTRES ATTACHED WITH MILK UNION, SIRSA

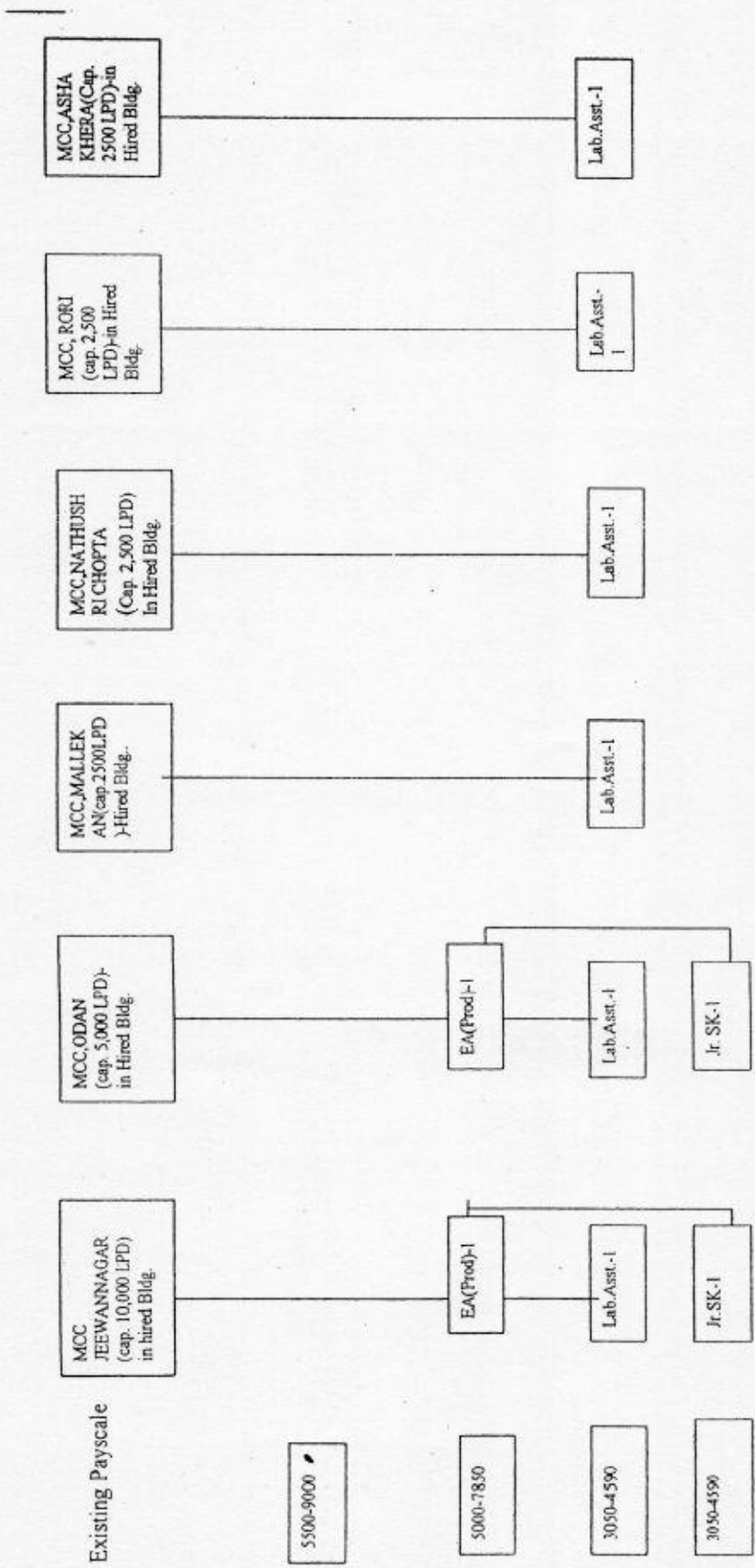

Figs. given above denotes requirement

Note: I) On page-1 figs. in parenthesis () denotes existing staff strength and figs. parallel to it indicates requirement of staff.
 II) DGM stands for Deputy General Manager, AGM- Asstt. General Manager, Mgr.-Manager, AM-Asstt. Manager
 EA-Executive Asstt

MU SIRSA

Section	Posts Sanctioned	Existing	Required*	Dimin. cadre	Addl. Posts required
CEO/GM	1	0	1	0	1
Procurement	36	30	27	8	5
Production & Engg.	93	30	55	2	27
Quality Control	12	6	18	1	13
Accounts	10	5	8	0	3
Admn. Store & Purchase	24	20	22	6	8
MIS	1	2	3	2	3
Marketing	3	0	7	0	7
Total	180	93	141	19	67

* includes the staff requirement of the Milk Chilling centres

Jobs given /to be given on contract basis

- Security
- Crate washing/Crate Loading/Unloading
- Operation of Pouch filling Machines
- Can washing
- Firing of oil in Boilers
- Packing of Powder/Ghee and transfer of the products to stores
- Loading of Milk Products in trucks
- Sweeping and sewerage cleaning
- Gardening/maintenance of lawns etc.
- E.T.P. Operation
- Sorting of pouches.
- Ghee filling, pouching and packing
- Resource persons to be deployed to strengthen the field activity for milk procurement enhancement
- If the union intends to get any other job done on contract basis, other than the jobs listed above, they may do so after seeking the approval from the BODs of the Milk Union.

MILK UNION, SIRSA

Other assumptions

1. Post of Steno in the payscale of Rs.5000-7850 has been clubbed with the post of EA. (Admn).
2. One Executive Asstt. (Proc.) will be posted against 25 functional societies(average for the year). After increase of every 25 functional socs. one additional post of EA (Proc) be created.
3. One AM(Proc) will be posted against 150 societies (average for the year)
4. One Mgr.(Proc.) will be posted against 400 societies(average for the year)
5. Promotion to the higher post from EA(proc) to the post of DGM(P&I) will be made when besides fulfilling functional societies criteria the milk procurement of the union in terms of average milk procurement/society/day is equivalent to the State average milk procurement/ society/day. The figure of the union will be compared with the average of the last 3 years of the State as a whole.
6. AGM & above on common cadre.
7. ** 100% posts under diminishing cadre.
* Posts under diminishing cadre.
8. No. of posts of driver will be according to the no. of vehicles plying in the union.
10. As and when a new milk chilling centre will be set up the posts for these chilling centres will be created on the pattern recommended for other chilling centres seperately.
11. A civil Engg. Cell will be created at the Federation level. The requirement of the post of JE(civil) will be met out of the staff to be provided at the Federation level.
12. As & when a new Sale Depots will be opened staff will be positioned in the Sale Depot/s as under:
In the Sale Depot with a annual turnover less than Rs 5.00 crores one post of AM(Mktg), one EA(mktg) and one Clerk will be provided. In the Sale Depot with a annual turnover of more than Rs. 5.00 crores one post of Mgr(Mktg), one EA(Mktg) and one clerk will be provided.
13. Post of FDO in the payscale of Rs. 6500-9900 will be designated as Manager(Inputs) and their requirement has been shown under the category of post Manager(Proc./Inputs)

MILK UNION, SIRSA**Career/Succession Planning**

To ensure better prospects and to avoid frustration/stagnation, persons incumbents of the post will be elevated to the higher post after certain period of regular satisfactory service in the pay scale.

However, out of the posts of AGM in the pay scale of Rs. 8000-13500 and DGM in the pay scale of Rs. 10000-15200 only one post will be filled up at a time. If AGM is promoted to the post of DGM, then the post of AGM from where he is promoted will remain vacant.

CHIEF EXECUTIVE OFFICER/GM

10000-15200 Existing Pay scale
 13500-17250 Proposed Payscale

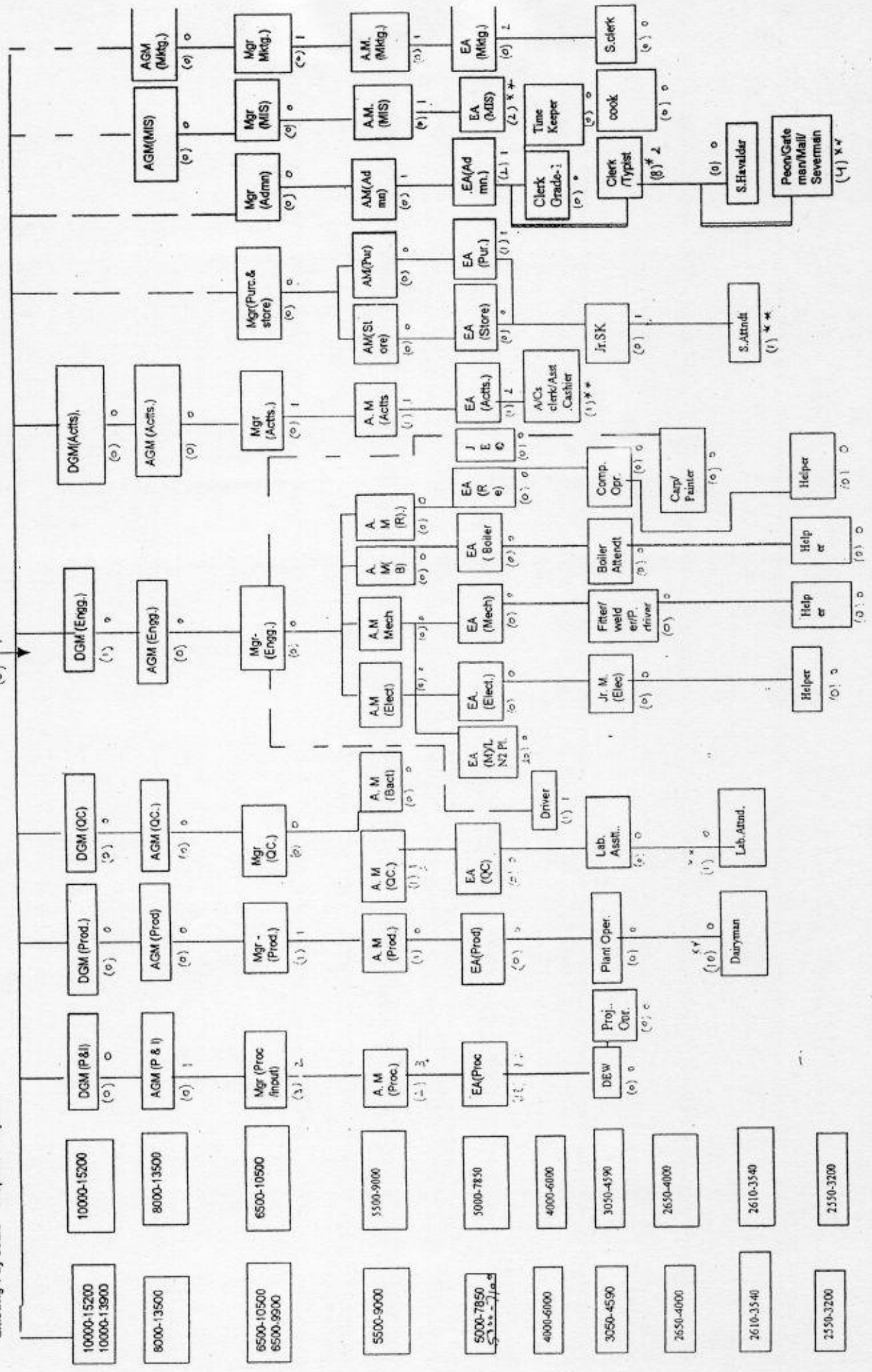

RECOMMENDED ORGANISATIONAL STRUCTURE OF MILK CHILLING CENTRES ATTACHED WITH MILK UNION, KURUK.-KARNAL

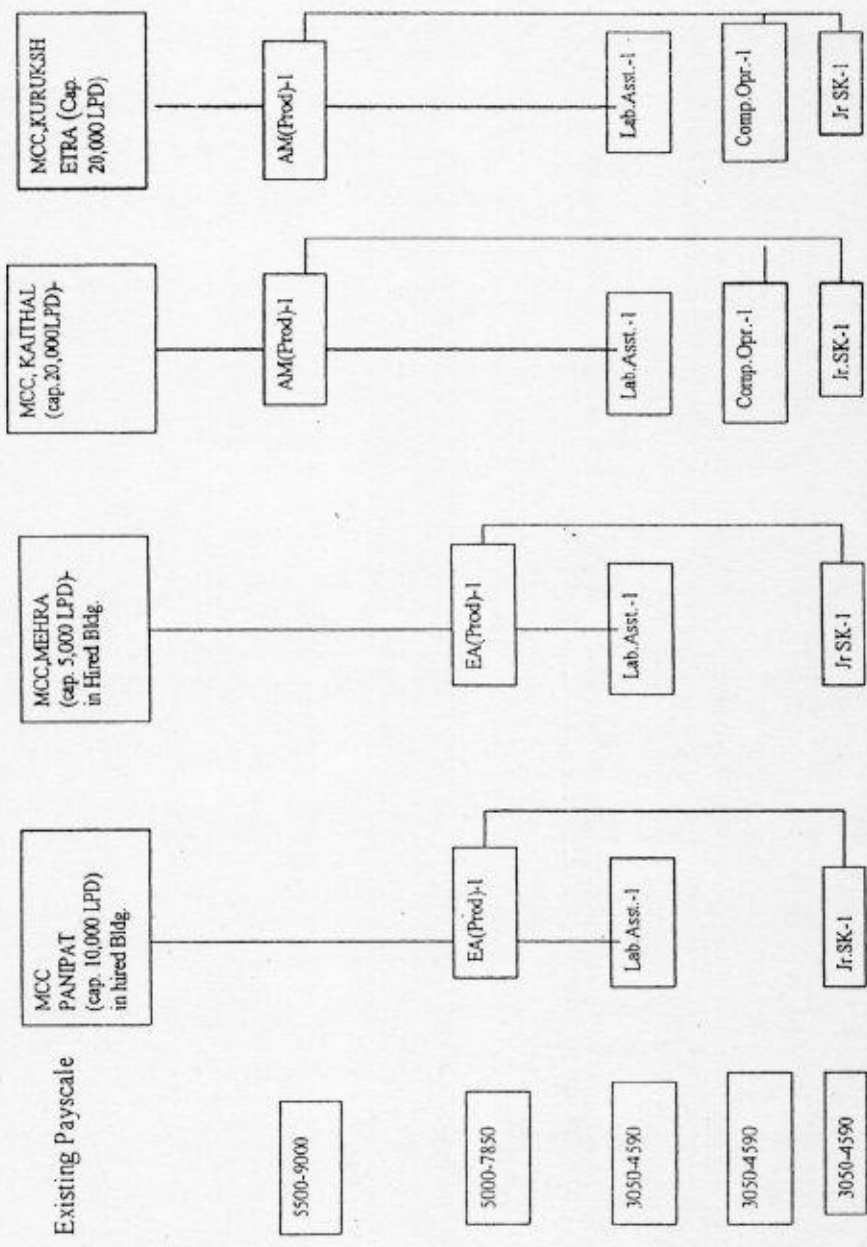

Figs. given above denotes requirement

Note: 1) On page-1 figs. in parenthesis () denotes existing staff strength and figs. parallel to it indicates requirement of staff.
 2) DGM stands for Deputy General Manager, AGM- Asstt. General Manager, Mgr.- Manager, AM-Asstt. Manager EA-Executive Asstt.

MU KURUKSHETRA-KARNAL

Section	Posts Sanctioned	Existing	Required*	Dimin. cadre	Addl. Posts required
CEO	1	0	1	0	1
Procurement	62	23	22	3	2
Production & Engineering	35	14	8	11	5
Quality Control	6	2	5	1	4
Accounts	10	3	4	1	2
Admn; Store & Purchase	27	16	10	12	6
MIS	2	2	1	2	1
Marketing	0	0	4	0	4
Total	143	60	55	30	25

* includes the staff requirement of the Milk Chilling centres

Jobs given /to be given on contract basis

- Can washing
- Sweeping and sewerage cleaning
- Gardening/maintenance of lawns etc.
- Security
- Resource persons to be deployed to strengthen the field activity for milk procurement enhancement.
- If the union intends to get any other job done on contract basis, other than the jobs listed above, they may do so after seeking the approval from the BODs of the Milk Union.

Other assumptions

1. Post of Steno in the payscale of Rs.5000-7850 has been clubbed with the post of EA.(Admn).
2. One Executive Assit. (Proc.) will be posted against 25 functional societies(average for the year).
After increase of every 25 functional socs. one additional post of EA (Proc) be created.
3. One AM(Proc) will be posted against 150 societies (average for the year)
4. One Mgr.(Proc.) will be posted against 400 societies(average for the year)
5. Promotion to the higher post from EA(proc) to the post of DGM(P&I) will be made when besides fulfilling functional societies criteria the milk procurement of the union in terms of average milk procurement/society/day is equivalent to the State average milk procurement/ society/day. The figure of the union will be compared with the average of the last 3 years of the State as a whole.
6. AGM & above on common cadre.
7. ** 100% posts under diminishing cadre.
* Posts under diminishing cadre.
8. No. of posts of driver will be according to the no. of vehicles plying in the union.
10. As and when a new milk chilling centre will be set up the posts for these chilling centres will be created on the pattern recommended for other chilling centres seperately.
11. A civil Engg. Cell will be created at the Federation level. The requirement of the post of JE(civil) will be met out of the staff to be provided at the Federation level.
12. As & when a new Sale Depot/s will be opened staff will be positioned in the Sale Depot/s as under:
In the Sale Depot with a annual turnover less than Rs 5.00 crores one post of AM(Mktg),one EA(mktg) and one Clerk will be provided.In the Sale Depot with a annual turnover of more than Rs. 5.00 crores one post of Mgr(Mktg),one EA(Mktg) and one clerk will be provided.
13. Post of FDO in the payscale of Rs. 6500-9900 will be designated as Manager(Inputs) and their requirement has been shown under the category of post Manager(Proc./Inputs)

MILK UNION, KURUKSHETRA-KARNAL

Career/Succession Planning

To ensure better prospects and to avoid frustration/stagnation, persons/incumbents of the post will be elevated to the higher post after certain period of regular satisfactory service in the pay scale.

However, out of the posts of AGM in the payscale of Rs. 8000-13500 and DGM in the payscale of Rs. 10000-15200 only one post will be filled up at a time. If AGM is promoted to the post of DGM, then the post of AGM from where he is promoted will remain vacant.



HDDCF

Section	Posts Sanctioned*	Existing**	Required***		Dimin. cadre	Addl. Posts required
			To be sent on deputation to Milk Unions	Federation		
				Total		
Managing Director	1	1		1		
Chief Admn. Officer	1	1		1		
Procurement & Cooperation	4	2	11	3	2	14
Production, Quality Control, Engineering & Transport	20	13	41	19	1	48
Accounts	18	10	10	10	3	13
Admn.; Store & Purchase	86	48	0	25	28	5
Plng, MIS & Systems	4	2	5	8	0	11
Marketing	13	13	5	8	8	8
Total	147	90	72	75	42	99

* includes the sanctioned staff strength of Sale Depots

** includes the existing staff strength of Sale Depots Chandigarh & Parwanoo & Delhi

*** In Accounts & Admn. Section the staff strength of SBTC, Rohtak has also been included.

HDDCF

Note: i) No. of posts of driver will be according to the no. of vehicles plying.
 ii) CGM stands for Chief General Manager, GM-General Manger, DGM -Deputy General Manager,
 AGM- Asstt. General Manager ,Mgr.-Manager, AM-Asstt. Manager, EA-Executive Asstt.
 PS-Private Secretary

Jobs given /to be given on contract basis

1. Sale counters will be outsourced.

Other assumptions

1. AGM & above on common cadre.
2. A Civil Engineering cell will be created at the Federation level. Requirement of the post of JE(civil) of Milk Unions will be met out of the staff to be provided at the Federation level.

Designations of the different posts in civil engineering cell have been kept at par with the ones existing in Govt. Deptts. It will facilitate to borrow the services of an employee holding a similar post in the Govt. Deptts.

HDDCF

Career/Succession Planning

To ensure better prospects and to avoid frustration/stagnation, persons incumbents of the post will be elevated to the higher post after certain period of regular satisfactory service in the pay scale.

However, out of the posts of General Manager in the payscale of Rs. 13500-17250 and Chief General Manager in the payscale of Rs. 18400-22400 only one post will be filled up at a time. If General Manager is promoted to the post of Chief General Manager then the post of General Manager from where he is promoted will remain vacant.

Similarly, out of the posts of AGM in the payscale of Rs. 8000-13500 and DGM in the payscale of Rs. 10000-15200 only one post will be filled up at a time. If AGM is promoted to the post of DGM then the post of AGM from where he is promoted will remain vacant.

RECOMMENDED ORGANISATIONAL STRUCTURE OF SEMEN BANK CUM TRAINING CENTRE CUM MINERAL MIXTURE PLANT, ROHTAK

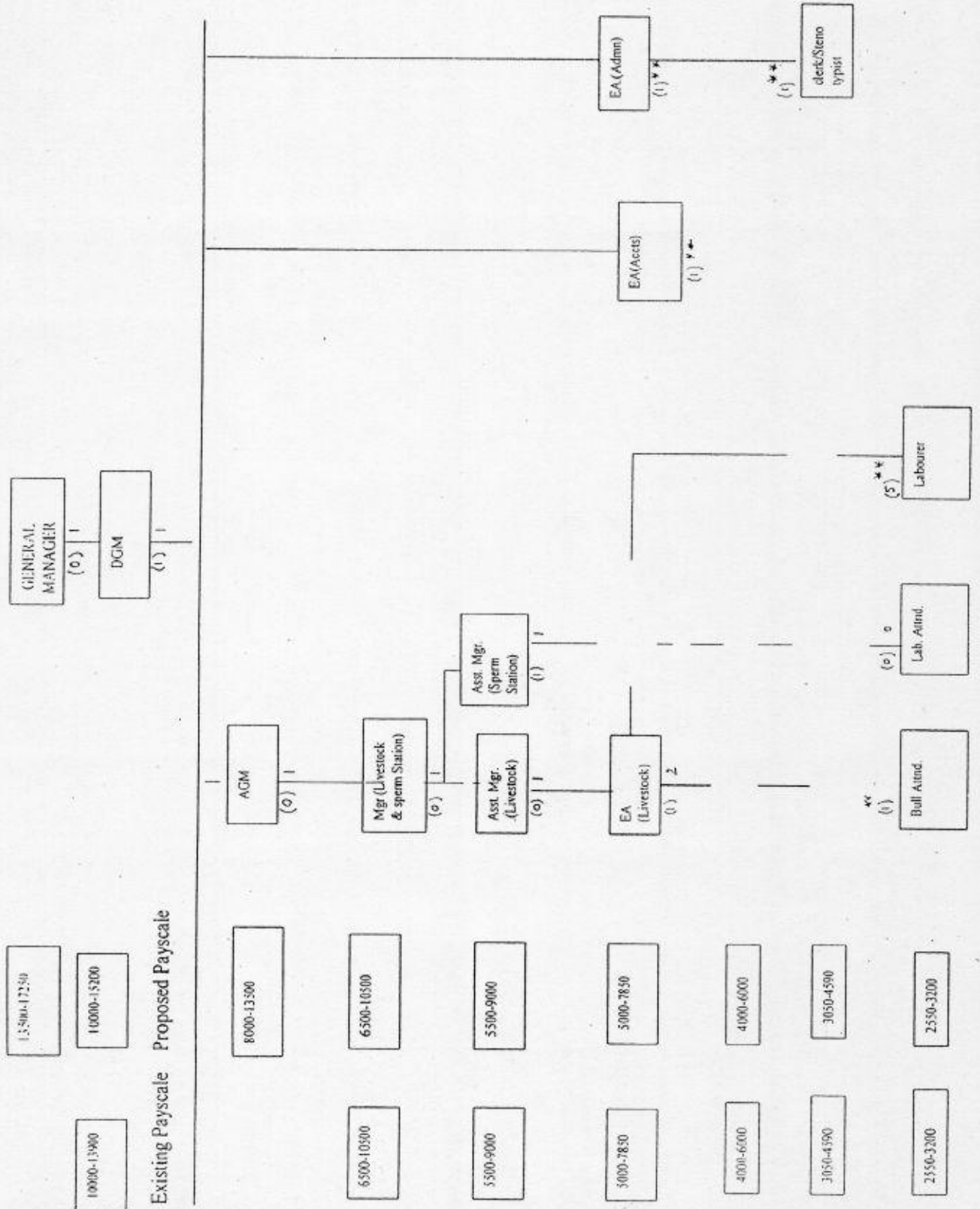

SEMEN BANK CUM TRAINING CENTRE CUM MINERAL MIXTURE PLANT, ROHTAK

Section	Posts Sanctioned	Existing	Required	Dimin. cadre	Add. Posts required
GM	0	0	1	0	1
DGM	1	1	1	0	0
Others	25	11	6	9	4
Total	26	12	8	9	5

Assumptions

1. Requirement of Admn. & Accounts Section has been included in the organizational structure of Head Office of HDDCF.

2. The Incumbent of the the post of AGM will be a Veterinarian and the post will be filled up by 100% direct recruitment when DGM/GM Semen Bank retires.

** 100% Diminishing cadre

3. Out of three posts of General Manager (Semen Bank) in the payscale of Rs. 13500-17250 , DGM in the payscale of Rs. 10000-15200 and AGM in the payscale of Rs. 8000-13500 only one post will be filled up at a time.

4. The following staff will be engaged on contract

- i) Security Guard
- ii) Sweeper
- iii) Electrician/Mechanic for Mineral Mixture
- iv) Tractor Driver
- v) Peon
- vi) Mali
- vii) Bull attendant, Lab. Attendant
- viii) Labourers

QUALIFICATIONS & MODE OF RECRUITMENT IN THE UNION

1.	Chief Executive Officer /General manager	Promotion=100% Out of category of DGM(P&I),DGM(Prod) DGM(QC), DGM(Engg) or DGM(Accts) having 5 years experience as DGM(P&I), DGM(Prod), DGM(QC) , DGM(Engg), DGM(Accts)
<u>PROCUREMENT & INPUT(P&I)</u>		
2.	DGM (P&I)	Promotion = 100% Out of Category of AGM (P&I) having 5 years experience as AGM (P&I).
3.	AGM (P&I)	Direct = 50% 25% Promotion 75% Graduate in Dairying or Agri. Science or Veterinary Science. Marks 60% or above. 10 years experience in milk procurement & extension work in Supervisory capacity in Dairy Cooperatives on Anand Pattern. Must have a working knowledge of computer including MS Office (i.e. MS word,MS Excel ,Power Point). Age not more than 45 years. Promotion = 50% 75% Out of Category of Manager (Proc/input) having 5 years experience as Manager (Proc/Input).
4.	Manager (Proc/Input)	Promotion = 100% Out of category of Asst.Manager (Proc) having 5 years experience as Asst. Manager (Proc.).
5.	Asstt. Manager (Proc)	Direct = 50% 25% Graduate in Dairying or Agri. Science or Veterinary Science.Marks 60% or above. Must have a working knowledge of computer including MS Office (i.e. MS word,MS excel,Power Point).Age not more than 40 years. Promotion = 50% 75% Out of category of Executive Asst.(Proc) having 5 years experience as Executive Asst.(Proc.).
6.	Executive Asst.(Proc.)	Direct = 50% 25% Diploma in Dairying or Diploma in (Agri.). Marks 60% or above. Must have a working knowledge of computer including MS Office (i.e. MS word,MS excel, PowerPoint). Age not more than 40 years. Promotion = 50% 75% Out of category of DEW having 5 years experience as DEW. No further recruitment to be made to the post of DEW. 50: 50 ratio will be maintained till

		DEWs are promoted to the post of Exe. Asst. (Proc). Thereafter recruitment to the post of Executive Asst.(Procurement) will be 100% direct.
PRODUCTION(Prod.)		
7.	DGM(Production)	Promotion = 100% Out of Category of AGM (Production) having 5 years experience as AGM (Production).
8.	AGM (Production) <i>see page 251-252 also.</i>	Direct = 50% 25% Graduate in Dairying/Food Processing/Agri. Science. Marks 60% or above with 10 years experience in the Dairy Plant. Must have a working knowledge of computer including MS Office (i.e. MS word,MS excel,Power Point) Age not more than 45 years. Promotion = 50% 75% Out of Category of Manager (Prod) having 5 years experience as Manager (Prod).
9.	Manager (Prod)	Promotion = 100% Out of category of Asst. Manager (Prod) having 5 years experience as Asst. Manager (Prod.).
10.	Asstt. Manager (Prod) <i>see page 251-252 also.</i>	Direct = 50% 25% Graduate in Dairying or Food Processing or Agri. Science. Marks 60% or above. Must have a working knowledge of computer including MS Office (i.e. MS word,MS excel,Power Point).Age not more than 40 years. Promotion = 50% 75% Out of category of Executive Asst.(Prod) having 5 years experience as Executive Asst.(Prod). Must at least be diploma holder in Dairying or Food Processing or Agri. Science.
11.	Executive Asst.(Prod.)	Direct = 50% 25% Diploma in Dairying or Agr. Science or Food Processing. Marks 60% or above. Must have a working knowledge of computer including MS Office (i.e. MS word,MS excel,Power Point). Age not more than 40 years. Promotion = 50% 75% Out of category of Plant Operator with 7 years experience.
12.	Plant Operator <i>Qualification of computer knowledge waived off by the BOD vide agenda No. 14455/2009 see page 249</i>	Direct = 50% 25% Matric with ITI Certificate holder in the related field. Marks 60% or above. Must have a working knowledge of computer including MS Office (i.e. MS word,MS excel,Power Point). Age not more than 40 years.

		Promotion = 50% 75% Out of category of Dairyman having 5 years experience as Dairyman.
13.	Dairyman	Direct = 100% Qualification 10+2. Marks 60% or above. Age not more than 40 years.
<u>QUALITY CONTROL (QC)</u>		
14.	DGM (QC)	Promotion = 100% Out of Category of AGM (QC) having 5 years experience as AGM (QC).
15.	AGM(QC)	Direct = 50% 25% Graduate in Dairying or M.Sc. Dairy Bacteriology or M.Sc. Dairy Chemistry. Marks 60% or above with 10 years experience in Quality Control of milk and milk products. Must have a working knowledge of computer including MS Office (i.e. MS word, MS excel, Power Point). Age not more than 45 years. Promotion = 50% 75% Out of category of Manager (QC) having 5 years experience as Manager (QC).
16.	Manager (QC) <i>not approved by RGS while approving revised Organisation chart</i>	Promotion = 100% Out of category of Asst. Manager (QC)/Asst. Mgr. (Bact.) having 5 years experience as Asst. Manager (QC.).
17.	Asstt. Manager (QC)/ Asstt. Manager (Bacteriologist)	Direct = 50% 25% Graduate in Dairying or Food Processing or M.Sc. Dairy Chemistry or M.Sc. Dairy Bacteriology. Marks 60% or above. Must have a working knowledge of computer including MS Office (i.e. MS word, MS excel, Power Point). Age not more than 40 years. Promotion = 50% 75% Out of category of Executive Asst. (QC) having 5 years experience as Executive Asst. (QC). Must at least be B.Sc. Chemistry.
18.	Executive Asst. (QC)	Promotion = 100% Out of category of Laboratory Assistant having 7 years experience as Laboratory Assistant.
19.	Laboratory Assistant	Direct = 50% 25% B.Sc. with Chemistry as one of the subjects. Marks 60% or above. Must have a working knowledge of computer including MS Office (i.e. MS word, MS excel, Power Point). Age not more than 40 years.

		Promotion = 50% 75% Out of category of Laboratory Attendant with 5 years experience as Laboratory Attendant.
20.	Laboratory Attendant (Dairyman)	Direct = 100% Qualification 10+2 (Science). Marks 60% or above. Age not more than 40 years.
ENGINEERING (Engg.)		
21.	DGM (Engg.)	Promotion = 100% Out of Category of AGM (Engg.) having 5 years experience as AGM (Engg.).
22.	AGM (Engg.)	Direct = 50% 25% Graduate in Engg.- Mechanical /Electrical /Civil Marks 60% or above with 10 years experience in a related field. Must have a working knowledge of computer including MS Office (i.e. MS word,MS excel,Power Point). or M.Sc. Dairy Engg. Marks 60% or above with 5 years experience in a related field. Must have a working knowledge of computer including MS Office (i.e. MS word,MS excel,Power Point). Age not more than 45 years. Promotion = 50% 75% Out of Category of Manager (Engg.) having 5 years experience as Manager (Engg.).
23.	Manager (Engg.)	Promotion = 100% Out of category of Asst.Manager (Engg.) having 5 years experience as Asst.Manager (Engg.) in any field.
24.	Asstt. Manager (Engg.) – Electrical/Mechanical.	Direct = 50% 25% Diploma in relevant field with 5 years experience. Marks 60% or above. Must have a working knowledge of computer including MS Office (i.e. MS word,MS excel,Power Point). Age not more than 40 years. Promotion = 50% 75% Out of category of Exe.Asst. (Elec/Mech) having 5 years experience as Exe. Asst.(Elec./Mech). Must at least be JTI certificate holder in the relevant field.
25.	Asstt. Manager (Engg.) – Boiler	Promotion = 100% Out of category of Executive Asst.(Engg.) – Boiler having 5 years experience as Executive Asst. (Engg.) Boiler.
26.	Asstt. Manager (Engg.) – Refrigeration	Direct = 50% 25% Diploma in relevant field with 5 years experience. Marks 60% or above. Must have a working knowledge of computer including MS Office (i.e. MS word,MS excel,Power Point). Age not more than 40 years.

		Promotion = 50% 75% Out of category of Executive Asst.(Engg.) Refrigeration having 5 years experience as Executive Asst.(Engg.) - Refrigeration. Must at least be ITI certificate holder in the relevant field.
27.	Executive Asst.(Engg) – Electrical	Promotion = 100% Out of category of Junior Mechanic (Electrical) having 7 years experience as Junior Mechanic (Electrical).
28.	Executive Asst. (Engg) – Mechanical	Promotion = 100% Out of category of Junior Mechanic (Mechanical) having 7 years experience as Junior Mechanic (Mechanical).
29.	Executive Asst. (Engg) – Boiler	Promotion = 100% Out of category of Boiler Attendant having 7 years experience as Boiler Attendant. Must be possessing A Competency/Class-I certificate issued by Chief Inspector Boiler. In case the internal candidates do not possess the requisite qualification then 100% direct appointment.
30.	Executive Asst.(Engg) – Refrigeration	Promotion = 100% Out of category of Compressor Operator with 7 years experience as Compressor Operator.
31.	Junior Engineer (Civil)	Direct = 100% Qualification – Diploma in Civil Engineering. Marks 60% or above. Must have a working knowledge of computer including MS Office (i.e. MS word, MS excel, Power Point). Age not more than 40 years.
32.	Junior Mechanic (Electrical/ Mechanical)	Direct = 50% 25% Qualification – Matric with ITI certificate in the relevant field. Marks 60% or above. Must have a working knowledge of computer including MS Office (i.e. MS word, MS excel, Power Point). Age not more than 40 years. Promotion = 50% 75% Out of category of Helper having experience of 10 years as helper in the relevant field.
33.	Welder/Fitter/Pump Driver (To be re-designated as Junior Mechanic (Mechanical))	Direct = 50% 25% Matric with ITI in relevant field. Marks 60% or above. Must have a working knowledge of computer including MS Office (i.e. MS word, MS excel, Power Point). Age not more than 40 years. Promotion = 50% 75% Out of category of Helper having experience of 10 years as helper in the relevant field.
34.	Boiler Attendant	Direct = 50% 25%

	<i>Boiler Attendant</i>	<p>Matric with B. Competency / Class II Certificate issued by Chief Inspector of Boiler. Marks 60% or above. Must have a working knowledge of computer including MS Office (i.e. MS word, MS excel, Power Point). Age not more than 40 years.</p> <p>Promotion = 50% 75% Out of category of Helper having experience of 10 years as helper. Must be possessing B. Competency / Class II Certificate issued by Chief Inspector of Boiler.</p>
35.	Compressor Operator <i>Qualification of Computer knowledge waived off by the BOD vide resolution No. 14/155/2009 see page 249</i>	<p>Direct = 50% 25% Matric with ITI in the relevant field. Marks 60% or above. Must have a working knowledge of computer including MS Office (i.e. MS word, MS excel, Power Point). Age not more than 40 years.</p> <p>Promotion = 50% 75% Out of category of Helper having experience of 10 years as helper in the relevant field.</p>
36.	Helper	<p>Direct = 100% Qualification Matric. Marks 60% or above. Age not more than 40 years.</p>
TRANSPORT		
37.	Driver <i>Matric</i>	<p>Direct = 100% <i>from Recognised Institute</i> 10+2 with Marks 60% or above, with driving licence of heavy vehicle, at least 3 years experience of driving a vehicle. Age not more than 40 years. Direct 25% Promotions 5%</p>
ACCOUNTS (Acctts)		
38.	DGM (Acctts)	<p>Promotion = 100% Out of Category of AGM (Acctts) having 5 years experience as AGM (Acctts).</p>
39.	AGM (Acctts)	<p>Direct = 50% 25% Chartered Accountant / Institute of Cost and Works Accountants/ Company Secretary/ MBA(Finance), marks 60% or above only in case of MBA(Finance), with 5 years post qualification experience in Accounts & Financial Management. Must have a working knowledge of computer including MS Office (i.e. MS word, MS excel, Power Point). Age not more than 45 years.</p> <p>Promotion = 50% 75% Out of Category of Manager (Acctts) having 5 years experience as Manager (Acctts).</p>
40.	Manager (Acctts)	<p>Promotion = 100% Out of category of Asst. Manager (Acctts) having 5 years experience as</p>

		Asst .Manager(Acctts.).
41	Asstt. Manager (Acctts)	<p>Direct = 50% 25% B.Com with marks 60% or above (proficiency in running TALLY PACKAGE or equivalent thereof is a must) with 2 years experience in the related field. Also must have a working knowledge of computer including MS Office (i.e. MS word,MS excel,Power Point). Age not more than 40 years</p> <p>Promotion = 50% 75% Out of category of Executive Asst. (Acctts) having 5 years experience as Executive Asst. (Acctts.)</p>
42.	Executive Asst.(Acctts)	<p>Direct = 50% 25% B.Com with marks 60% or above (proficiency in running TALLY PACKAGE or equivalent thereof is a must). Also must have a working knowledge of computer including MS Office (i.e. MS word,MS excel,Power Point). Age not more than 40 years.</p> <p>Promotion = 50% 75% Out of category of Accounts Clerk/Asstt. cashier with 5 years experience as Accounts Clerk/Asstt. cashier. No further recruitment to be made to the post of Accounts Clerk/Asstt. Cashier. 50:50 ratio will be maintained till the Accounts Clerks/Asstt. Cashier are promoted to the post of Junior Executive (Acctts). Thereafter the recruitment to the post of Junior Executive (Acctts) will be 100% direct.</p>
PURCHASE & STORE		
43.	Manager (Purchase & Stores)	<p>Promotion = 100% Out of category of Asst. Manager (Purchase/ Store) having 5 years experience as Asst. Manager (Purchase/ Stores).</p>
44.	Asstt. Manager (Purchase)/ Asst. Manager(Stores)	<p>Promotion = 100% Out of category of Executive Asst. (Purchase)/ Executive Asst.(Store) having 5 years experience as Executive Asst. (Purchase) / Executive Asst.(Stores).</p>
45.	Executive Asst.(Stores)/ Executive Asst.(Purchase)	<p>Direct = 50% 25% B.Com. Marks 60% or above with 1 year experience. Must have a working knowledge of computer including MS Office (i.e. MS word,MS excel,Power</p>

		Point). Age not more than 40 years. Promotion = 50% 75% Out of category of Junior Store Keeper/Asstt. Store Keeper/ Purchase Clerk having 5 years experience as Junior Store Keeper/ Asstt. Store Keeper/ Purchase Clerk .
46	Junior Store Keeper/Asstt. Store keeper/Purchase clerk	Direct = 50% 25% B.Com. Marks 60% or above. Must have a working knowledge of computer including MS Office (i.e. MS word,MS excel,Power Point). Age not more than 40 years. Promotion = 50% 75% Out of category of Store Attendant having 5 years experience as Store Attendant. Must at least be Matriculate.
47	Store Attendant	Direct=100% 10+2 qualification. Marks 60% or above. Age not more than 40 years.
ADMINISTRATION(Admn)		
48.	Manager (Administration)	Promotion = 100% Out of category of Asst. Manager (Administration) having 5 years experience as Asst. Manager (Administration).
49.	Asstt. Manager (Administration)	Direct = 50% 25% Graduate having 3 years experience of dealing in Establishment matters or LLB or Graduate with 2 years Diploma in Management. Marks 60% or above. Must have a working knowledge of computer including MS Office (i.e. MS word,MS excel,Power Point). Age not more than 40 years. Promotion = 50% 75% Out of category of Executive Asst.(Administration)/ Stenographer having 5 years experience as Executive Asst.(Administration) / Stenographer.
50.	Executive Asst. (Administration)/ Stenographer.	Promotion = 100% Stenographer Out of category of Time Keeper/Clerk Grade-1 having 5 years experience as Time Keeper/Clerk Grade-1and Out of category of Clerks/Typists/ Steno Typist having 7 years experience as Clerk /Typist/ StenoTypist. No further recruitment to be made to the post of Time keeper/clerk Grade-1 Executive (Administration) Promotion 75%, Direct 25%
51	Steno Typist	Direct = 100% Graduate, marks 60% or above with minimum typing speed in English of 35

		words per minute on computer and shorthand speed 80 w.p.m. or typing speed in Hindi 30 w.p.m. on computer and shorthand 64 w.p.m. Must be proficient in operating computer. Age not more than 40 years. Promotion = Nil.
52.	Clerk/Typist	Direct = 50% 75% Graduate, marks 60% or above. Typing speed English 35 w.p.m. or Hindi 25 w.p.m on computer. Must be proficient in operating computer. Age not more than 40 years. Promotion = 50% 25% Out of category of Peon/Gateman/Mali/Sweeper/Bull Attendant/Labourer/Van Attendant having 10 years experience as Peon/Gateman/Mali/Sweeper/Bull Attendant/Labourer/Van Attendant. Must at least be Matriculate. Further promotion will be subject to passing of a test.
53	Peon/Gateman/Mali/Sweeper/Bull Attendant/Labourer/Van Attendant	Direct=100% Qualification – Matric. Marks 60% or above. Age not more than 40 years.
PLNG; MIS & SYSTEMS		
54	AGM (MIS)	Direct = 50% 25% M.Sc. (Dairy Economics) or M.A. Economics/ Mathematics/ Statistics /M.B.A./ MCA/ Or Graduate with 2 years Diploma in Management Or B.Sc. Dairying/Food Processing/ Agri. Science. Marks 60% or above with 10 years experience in MIS. Must have a knowledge of computer programming. Age not more than 45 years. Promotion = 50% 75% Out of Category of Manager (MIS) having 5 years experience as Manager (MIS).
55.	Manager (MIS)	Promotion = 100% Out of category of Asst. Manager (MIS) having 5 years experience as Asst. Manager (MIS.).
56.	Asstt. Manager (MIS)	Direct = 50% 25% B.C.A./B.Com/B.Sc. with 3 years experience in MIS

		<p>or B.Sc. Dairying/ Food Processing/Agr. Science. Marks 60% or above. Must have a knowledge of computer programming. Age not more than 40 years.</p> <p>Promotion = 50% 75% Out of category of Executive Asst.(MIS) having 5 years experience in MIS.. No further recruitment to be made to the post of Exe.Asst.(MIS). 50: 50 ratio will be maintained till the MIS Assistant /Statistical Asstts.(redesignated as Exe. Asst.(MIS) are promoted to the post of Asstt. Mgr.(MIS). Thereafter the recruitment to the post of Asst. Manager(MIS) will be 100% direct.</p>
<u>MARKETING (Mktg)</u>		
57.	AGM (Mktg)	<p>Direct = 50% 25% MBA or Post Graduate Diploma in Management equivalent to MBA from recognized University/Institute. Marks 60% or above with 5 years experience in Marketing of Fast Moving Consumer Goods. Must have a working knowledge of computer including MS Office (i.e. MS word,MS excel,Power Point). Age not more than 45 years.</p> <p>Promotion = 50% 75% Out of Category of Manager (Mktg) having 5 years experience as Manager (Mktg).</p>
58	Manager (Mktg)	<p>Promotion = 100% Out of category of Asst. Manager (Mktg) having 5 years experience as Asst. Manager (Mktg.).</p>
59	Asstt. Manager (Mktg)	<p>Promotion = 100% Out of category of Executive Asst.(Mktg) with 5 years experience as ExecutiveAsst.(Mktg).</p>
60.	Executive Asst.(Mktg)	<p>Direct = 50% 25% Graduate with Diploma in Marketing Management. Marks 60% or above.Must have a working knowledge of computer including MS Office (i.e. MS word,MS excel,Power Point). Age not more than 40 years.</p> <p>Promotion = 50% 75% Out of category of Sale Clerk with 7 years experience in Marketing.</p>
61.	Sale Clerk	<p>Direct=100% Graduate or 10+2 with Diploma in</p>

		Marketing. Marks 60% or above. Must have a working knowledge of computer including MS Office (i.e. MS word,MS excel,Power Point). Age not more than 40 years.
--	--	---

ANNEXURE-B

QUALIFICATIONS & MODE OF RECRUITMENT IN THE FEDERATION

1.	Managing Director	<p>To be appointed by the Govt. as per provisions of Haryana Cooperative Societies Act, 1984. Where no such appointment is made by Govt. direct appointment to be made by Personnel Committee as per following qualifications</p> <p>Direct=100% Degree in Dairy Technology/Food Technology/Engineering /Animal Husbandry, with MBA or Post Graduate Diploma in Management equivalent to MBA. Or Chartered Accountant or M.Com. or MA Economics with Master of Business Administration or Post Graduation Diploma in Management equivalent to MBA. Marks 60% or above. 15 years experience out of which 10 years in a Senior Managerial Position in processing unit of repute. Age not more than 50 years.</p> <p>Promotion=Nil</p>
2.	Chief Administrative Officer	<p>To be appointed by the Govt. Where no such appointment is made by Govt. direct appointment to be made as per following qualifications</p> <p>Direct=100% Law Graduate with MBA or Post Graduate Diploma equivalent to MBA. Marks 60% or above. 12 years experience of dealing matters relating to Establishment & labour laws in an organization of repute. Age not more than 50 years.</p> <p>Promotion=Nil</p>
<u>PROCUREMENT & INPUT (P&I)</u>		
3.	GM(P&I)	<p>Promotion = 100% Out of Category of DGM (P&I) having 5 years experience as DGM(P&I).</p>
4.	DGM (P&I)	<p>Promotion = 100% Out of Category of AGM(P&I) having 5 years experience as AGM(P&I).</p>
5.	AGM(P&I)	<p>Direct = 50% 25% Graduate in Dairying or Agri. Science or Veterinary Science. Marks 60% or above. 10 years experience in milk procurement & extension work in Supervisory capacity in Dairy Cooperatives on Anand Pattern. Must have a working knowledge of computer</p>

		including MS Office (i.e. MS word,MS Excel ,Power Point). Age not more than 45 years. Promotion = 50% 75% Out of Category of Manager (Proc./Input) of Annexure A having 5 years experience as Manager (Proc. /Input)
6.	Manager (Proc & coop.)	Promotion = 100% Out of category of Asst. Manager (Proc & coop.) having 5 years experience as Asst. Manager (Proc & coop.).
7.	Asstt. Manager (Proc& coop.)	Direct = 50% 25% Graduate in Dairying or Agri. Science or Veterinary Science. Marks 60% or above. Must have a working knowledge of computer including MS Office (i.e. MS word,MS excel,Power Point) Promotion = 50% 75% Out of category of Executive Asst. (Proc/coop.) having 5 years experience as Executive Asst. (Proc./coop.). No further recruitment to be made to the post of Exe. Asst.(Proc./coop.). 50: 50 ratio will be maintained till Exe. Asst.(Proc./coop.) are promoted to the post of Asstt. Mgr.(Proc & coop.). Thereafter the recruitment to the post of Asst. Manager(Proc & coop.) will be 100% direct.
PRODUCTION & TECHNICAL(PROD. & Tech.)		
8	CGM(Prod. & Tech.)	Promotion=100% Out of category of General Manager (Tech.)or General Manager (Plants) having 5 years experience as General Manager(Tech.) or General Manager(Plants)
9	GM(Tech.)	Promotion=100% Out of category of DGM(Prod) , DGM(QC), DGM.(Engg) having 5 years experience as DGM (Prod) or DGM (QC)or DGM.(Engg)
10.	DGM (Prod.)	Promotion = 100% Out of Category of AGM (Prod) having 5 years experience as AGM(Prod.).
11.	AGM(Prod)	Direct = 50% 25% Graduate in Dairying/Food Processing/Agri. Science. Marks 60% or above with 10 years experience in the Dairy Plant. Must have a working knowledge of computer including MS Office (i.e. MS word,MS excel,Power Point) Age not more than 45 years. Promotion = 50% 75% Out of Category of Manager (Prod) of annexure-A having 5 years experience as Manager (Prod).

QUALITY CONTROL (QC)

12.	DGM (QC)	Promotion = 100% Out of Category of AGM (QC) having 5 years experience as AGM (QC).
13.	AGM (QC)	Direct = 50% 25% Graduate in Dairying or M.Sc. Dairy Bacteriology or M.Sc. Dairy Chemistry marks 60% or above with 10 years experience in Quality Control of milk and milk products. Must have a working knowledge of computer including MS Office (i.e. MS word,MS excel,Power Point) Age not more than 45 years. Promotion = 50% 75% Out of category of Manager (QC) of Annexure-A and Annexure-B having 5 years experience as Manager (QC).
14.	Manager (QC)	Direct = 100% Graduate in Dairying or M.Sc. Dairy Bacteriology or M.Sc. Dairy Chemistry marks 60% or above with 5 years experience in Quality Control of milk and milk products. Must have a working knowledge of computer including MS Office (i.e. MS word,MS excel,Power Point). Age not more than 40 years.
<u>ENGINEERING (Engg.)</u>		
15.	DGM(Engg.)	Promotion = 100% Out of Category of AGM (Engg.) having 5 years experience as AGM (Engg.).
16.	AGM(Engg)	Direct = 50% 25% Graduate in Engg.- Mechanical /Electrical /Civil Marks 60% or above with 10 years experience in a related field. Must have a working knowledge of computer including MS Office (i.e. MS word,MS excel,Power Point). or M.Sc. Dairy Engg. Marks 60% or above with 5 years experience in a related field. Must have a working knowledge of computer including MS Office (i.e. MS word,MS excel,Power Point). Age not more than 45 years. Promotion = 50% 75% Out of Category of Manager (Engg.) of Annexure-A & annexure-B having 5 years experience as Manager (Engg.).
17.	Manager (Engg.)	Promotion = 100% Out of category of Asst. Manager (Engg.) having 5 years experience as Asst. Manager

		(Engg.).
18.	Asstt. Manager (Engg.)	<p>Direct = 50% 25% Diploma in Mechanical Engg., marks 60% or above with 5 years experience. Must have a working knowledge of computer including MS Office (i.e. MS word, MS Excel, Power Point).</p> <p>Promotion = 50% 75% Out of category of Exe. Asst.(Mech)/Draftsman (Mech) to be redesignated as Exe. Asst.(Mech.) having 5 years experience as Exe. Asst.(Mech). Must at least be ITI certificate holder in the relevant field.</p>
CIVIL ENGINEERING		
19	Executive Engineer- (XEN)civil	Promotion=100% Out of category of SDO(civil) having 5 years experience as SDO (civil)
20	Sub- Divisional Officer(SDO)-civil	<p>Direct = 50% 25% Graduate in Civil Engineering marks 60% or above with 10 years experience in the related field. Must have a working knowledge of computer including MS Office (i.e. MS word, MS excel, Power Point). Age not more than 45 years</p> <p>Promotion = 50% 75% Out of category of Junior Engineer(civil)/Draftsman (Civil) to be redesignated as Junior Engineer(civil) with 10 years experience as Junior Engineer(civil).</p>
21.	Junior Engineer (Civil)	<p>Direct = 100% Qualification – Diploma in Civil Engineering. Marks 60% or above. Must have a working knowledge of computer including MS Office (i.e. MS word, MS excel, Power Point). Age not more than 40 years.</p>
TRANSPORT		
22.	Driver <i>10/11/11/2007</i>	<p>Direct = 100% 25% Promotion 75% 10+2 marks 60% or above with driving licence of heavy vehicle, at least 3 years experience of driving a vehicle. Age not more than 40 years.</p>
ACCOUNTS & FINANCE(Accts & Fin.)		
23	CGM(Accts & Fin.)	Promotion=100% Out of category of General Manager (Accts.& Fin.) having 5 years experience as General Manager (Accts

		& Fin.)
24	General Manager(Accts& Fin.)	Promotion=100% Out of Category of DGM(Acctts) having 5 years experience as DGM(Acctts).
25	DGM(Acctts & Fin.)	Promotion = 100% Out of category of AGM (Acctts) having 5 years experience as AGM(Acctts).
26.	AGM(Acctts)	Direct = 50% 25% Chartered Accountant / Institute of Cost and Works Accountants/ Company Secretary/ MBA(Finance), Marks 60% or above only in case of MBA(Finance), with 5 years post qualification experience in Accounts & Financial Management. Must have a working knowledge of computer including MS Office (i.e. MS word,MS excel,Power Point). Age not more than 45 years. Promotion = 50% 75% Out of Category of Manager (Acctts) of Annexure-A and Manager (Acctts)/ Manager(Audit) of Annexure-B having 5 years experience as Manager (Acctts) / Manager(Audit).
27.	Manager (Acctts)/ Manager(Audit)	Promotion = 100% Out of category of Asst. Manager (Acctts) having 5 years experience as Asst.Mgr.(Acctts.).
28	Asstt. Manager (Acctts)	Direct= 50% 25% B.Com, Marks 60% or above. (proficiency in running TALLY PACKAGE or equivalent thereof is a must) with 2 years experience in the related field. Also must have a working knowledge of computer including MS Office (i.e. MS word,MS excel,Power Point). Promotion = 50% 75% Out of category of Executive Asst.(Acctts) having 5 years experience as Executive Asst. (Acctts.)
29.	Executive Asst.(Acctts)	Direct = 50% 25% B.Com Marks 60% or above. (proficiency in running TALLY PACKAGE or equivalent thereof is a must). Also must have a working knowledge of computer including MS Office (i.e. MS word,MS excel,Power Point). Age not more than 40 years. Promotion = 50% 75% Out of category of Accounts Clerk/Asstt. cashier with 5 years experience as Accounts Clerk/Asstt. cashier. No further recruitment to be made to the

		post of Accounts Clerk/Asstt. Cashier. 50:50 ratio will be maintained till the Accounts Clerks/Asstt. Cashier are promoted to the post of Junior Executive (Acctts). Thereafter the recruitment to the post of Junior Executive (Acctts) will be 100% direct.
HRD, PURCHASE & STORE (HRD, Pur. & Store)		
30.	DGM(HRD, Pur. & Store)	Promotion=100% Out of category of AGM.(HRD, Pur. & Store) having 5 years experience as AGM(HRD, Pur. & Store)
31.	AGM(HRD, Pur. & Store)	Direct = 50% 25% MBA or Graduate with 2 years Diploma in Management or LLB from recognized university/Institute marks 60% or above with 10 years experience in HRD, Pur. & stores. Age not more than 45 years. Promotion = 50% 75% Out of category of Manager(Pur. & stores) or Manager(Admn.) of Annexure A and Manager (Admn.) of Annexure-B having 5 years experience as Manager (Pur. & Stores) or Manager(Admn.)
32.	Manager (Admn.)	Promotion = 100% Out of category of Asst. Manager (Admn) having 5 years experience as Asst. Manager (Admn.).
33.	Asstt. Manager (Admn.)	Promotion = 100% Out of category of Executive Asst.(Admn) having 5 years experience as Executive (Admn).
34.	Executive Asst. (Administration).	Direct = 50% 25% Graduate Marks 60% or above having 1 year experience of dealing in Establishment matters. Must have a working knowledge of computer including MS Office (i.e. MS word, MS excel, Power Point). Age not more than 40 years. Promotion = 50% 75% Out of category of Clerks/Typists having 7 years experience as Clerk /Typist.
35	Clerk/Typist <i>Amended vide resolution NO. 11168/2013. see page 258</i>	Direct = 50% 75%. Promotion 25% Graduate Marks 60% or above. Typing speed English 35 w.p.m. or Hindi 25 w.p.m on computer. Must be proficient in operating computer. Age not more than 40 years.

		Promotion = 50% Out of category of Jamadar having 5 years experience as Jamadar and out of category of Peon having 10 years experience as Peon. Must at least be Matriculate. Further promotion will be subject to passing of a test. No further recruitment to be made to the post of Jamadar.
36	Peon	Direct=100% Qualification – Matric. Marks 60% or above. Age not more than 40 years.
37	Manager(Private Secretary)	Promotion=100% Out of category of Asst. Mgr.(PA) having 5 years experience as Asst. Mgr.(PA)
38	Asstt.Mgr.(PA)	Promotion=100% Out of category of Exe. Asst.(stenographer) having 5 years experience as Exe. Asst.(stenographer)
39	.Exe. Asst.(stenographer)	Direct = 50% <i>NIL</i> Graduate Marks 60% or above with 1 year experience with minimum typing speed in English of 35 words per minute on computer and shorthand speed 80 w.p.m. or typing speed in Hindi 30 w.p.m. on computer and shorthand 64 w.p.m. Must be proficient in operating computer. Age not more than 40 years. Promotion = 50% <i>100%</i> Out of category of Steno Typist having 5 years experience as Steno Typist. No further recruitment to be made to the post of Steno-typist. 50: 50 ratio will be maintained till Steno Typists are promoted to the post of Exe. Asst.(stenographer). Thereafter the recruitment to the post of Exe. Asst.(stenographer) will be 100% direct.
<u>PLNG; MIS & SYSTEMS</u>		
40	GM(Plng;MIS & Systems)	Promotion = 100% Out of Category of DGM (Plng;MIS & Systems) having 5 years experience as DGM(Plng;MIS & Systems)
41	DGM(Plng;MIS & Systems)	Promotion=100% Out of category of AGM(MIS) or AGM(Systems) having 5 years experience as AGM (MIS) or AGM (Systems)
42	AGM (MIS)	Direct = 50% <i>25%</i> M.Sc. (Dairy Economics) or M.A.Economics/ Mathematics/ Statistics /M.B.A./ MCA Or Graduate with 2 years Diploma in Management

		<p>Or B.Sc.Dairying/Food Processing/ Agri. Science. Marks 60% or above with 10 years experience in MIS. Must have a knowledge of computer programming. Age not more than 45 years.</p> <p>Promotion = 50% 75% Out of category of Manager (MIS) of Annexure-A and Annexure-B having 5 years experience as Manager (MIS).</p>
43.	Manager (MIS)	<p>Promotion = 100% Out of category of Asst. Manager (MIS) having 5 years experience as Asst. Manager (MIS.).</p>
44.	Asstt. Manager (MIS)	<p>Direct = 50% 25% B.C.A./B. Com/B.Sc. with .3 years experience in MIS or or B.Sc. Dairying/ Food Processing/Agri. Science. Marks 60% or above. Must have a knowledge of computer programming. Age not more than 40 years.</p> <p>Promotion = 50% 75% Out of category of Executive Asst.(MIS) having 5 years experience in MIS. No further recruitment to be made to the post of.Exe. Asst.(MIS). 50: 50 ratio will be maintained till the MIS Assistant /Statistical Asstts.(redesignated as.Exe. Asst.(MIS) are promoted to the post of Asstt. Mgr.(MIS). Thereafter the recruitment to the post of Asst. Manger(MIS) will be 100% direct.</p>
45	AGM(Systems)	<p>Direct = 50% 25% MCA/M.Sc(IT)/MSc(Computer Science) Marks 60% or above with 10 years experience in ERP concept, Computer programming and website development. Age not more than 45 years.</p> <p>Promotion = 50% 75% Out of category of Manager (Systems) of Annexure-B having 5 years experience as Manager (Systems).</p>
46	Manager (Systems)	<p>Promotion = 100% Out of category of Asst. Manager (Systems) having 5 years experience as Asst. Manager (Systems).</p>

47	Asstt. Manager (Systems)	Direct = 100% MCAM.Sc(IT)/MSc(Computer Science) Marks 60% or above Age not more than 40 years.
<u>MARKETING (Mktg)</u>		
48	CGM(Mktg.)	Promotion=100% Out of category of General Manager (Mktg.) having 5 years experience as General Manager(Mktg.)
49	General Manager(Mktg)	Promotion=100% Out of category of DGM (Mktg.) having 5 years experience as DGM(Mktg)
50	DGM (Mktg)	Promotion=100% Out of category of AGM (Mktg.) , having 5 years experience as AGM(Mktg)
51	AGM (Mktg)	Direct = 50% 25% MBA or Post Graduate Diploma in Management equivalent to MBA from recognized University/Institute Marks 60% or above with 5 years experience in Marketing of Fast Moving Consumer Goods. Must have a working knowledge of computer including MS Office (i.e. MS word,MS excel,Power Point). Age not more than 45 years. Promotion = 50% 75% Out of Category of Manager (Mktg) of Annexure-A and Annexure-B having 5 years experience as Manager (Mktg).
52	Manager (Mktg)	Promotion = 100% Out of category of Asst. Manager (Mktg) having 5 years experience as Asst. Manager (Mktg.).
53	Asstt. Manager (Mktg)	Promotion = 100% Out of category of Executive Asst.(Mktg) with 5 years experience as Executive Asst. (Mktg).
54.	Executive Asst. (Mktg)	Direct = 50% 25% Graduate with Diploma in Marketing Management. Marks 60% or above. Must have a working knowledge of computer including MS Office (i.e. MS word,MS excel,Power Point). Age not more than 40 years. Promotion = 50% 75% Out of category of Sale Clerk with 7 years experience in Marketing.
55.	Sale Clerk	Direct=100% Graduate or 10+2 with Diploma in Marketing. Marks 60% or above. Must have a working knowledge of computer including MS Office (i.e. MS word,MS excel,Power Point). Age not more than

		40 years.
SEMEN BANK -CUM -TRAINING CENTRE,ROHTAK		
56	GM(Semen Bank)	Promotion = 100% Out of Category of DGM (Semen Bank)having 5 years experience as DGM(Semen Bank)
57	DGM(Semen Bank)	Promotion = 100% Out of Category of AGM(Semen Bank)having 5 years experience as AGM(Semen Bank).
58	AGM((Semen Bank)	Direct = 50% 25% Graduate in Veterinary Science. Marks 60% or above. 10 years experience in frozen semen technology. Must have a working knowledge of computer including MS Office (i.e. MS word,MS Excel ,Power Point). Age not more than 45 years. Promotion = 50% 75% Out of Category of Manager (Livestock & Sperm Station) having 5 years experience as Manager (Livestock & Sperm Station).
59	Manager (Livestock & Sperm Station)	Promotion = 100% Out of category of Asst.Manager (Livestock)/Asstt.Mgr.(Sperm Station) having 5 years experience as Asst.Manager (Livestock) /Asstt. Mgr. (Sperm Station).
60	Asstt. Manager (Sperm Station)	Direct = 100% Graduate in Veterinary Science,marks 60% or above. Must have a working knowledge of computer including MS Office (i.e. MS word,MS excel,Power Point).Age not more than 40 years.
61	Asstt. Manager(Livestock).	Promotion = 100% Out of category of Executive Asst. (Livestock) having 5 years experience as Executive Asst. (Livestock).
62	.Executive Asst.(Livestock).	Direct = 100% Diploma in Livestock Management. Marks 60% or above. Candidates having experience in artificial insemination or cattle management will be preferred. Must have a working knowledge of computer including MS Office (i.e. MS word,MS excel, PowerPoint). Age not more than 40 years.

		Office (i.e. MS word,MS excel, PowerPoint). Age not more than 40 years.
--	--	---

Note:

The following conditions will apply to all categories of posts wherever applicable

- The promotion shall be made on the basis of seniority-cum-merit and no employee shall have the right to promotion by virtue of seniority alone.
- In case there is one post to be filled up by direct recruitment(50%) and promotion (50%) then in the first instance it will be filled up by promotion and subsequently by direct recruitment and so on.
- Relaxation of 5 percentage points in qualification will be given to SC/ST/BC/OBC candidates of Haryana

Rajal

From

72

The Registrar,
Cooperative Societies Haryana,
Panchkula.

To

The Managing Director,
Haryana Dairy Dev. Coop. Fed. Ltd.,
Panchkula.

Memo No. 316105/MS 9/21-

dated 27/3/06

Sub: Organizational charts with revised qualifications and mode of recruitment in respect of Federation's Employees and common cadre employees.

The proposal sent by you has been examined and it has been found that it is necessary to make certain amendments in the proposal. The amended version showing the posts with numbers, qualifications and mode of recruitment in respect of Federation's Employees and common cadre employees is approved under section 37 of the Haryana Cooperative Societies Act 1984. You may now take further necessary action at your end.

Royal

Joint Registrar(Godown),
For Registrar Cooperative Societies Haryana,
Panchkula. h.s.

Endstt.No.

Dated

Financial Commissioner & Principal Secretary to Govt. Haryana,
Cooperation Deptt. with reference to their Memo No. 322-C-6-2006/3199
dated 17-3-06.

Sol

Joint Registrar(Godown),
For Registrar Cooperative Societies Haryana,
Panchkula.



HARYANA DAIRY DEVELOPMENT COOPERATIVE FEDERATION LTD.
Bay No. 21-22, Sahakarita Bhawan, Sector 2, PANCHKULA

ORDER

Consequent upon the implementation of revised organizational charts of the Federation and amendment in the Service Rules and receipt of approval of RCS, Haryana vide their Memo No. 316/05/M1/2121 dated 27.3.2006, under section 37 of Haryana Cooperative Societies Act, 1984, the nomenclature of the following posts is changed as under :-

Sr. N.	Existing Pay Scale	Existing Post / Designation	New Pay scale after change of nomenclature	Changed / New nomenclature of post
1.	12000-16500	Director (Prod. & projects) / Director (Mktg.)	18400-22400	Chief Gen. Manager
2.	10000-15200	General Manager(Projects) / General Manager Milk Plants / Project Officer	13500-17250	General Manager
3.	10000-13900	Manager (A&F)/ Manager (P&M)/ Manager (Prod.) / Dairy Engineer/ Mgr. (Semen Bank)	10000-15200	Dy.Gen. Manager
		XEN		XEN
4.	8000-13500	Deputy Manager (Prodn) / Dy. Manager (Acetts.) / Dy Manager (Q.C.) / Dy.Mgr.(P&M) / M(P&A) / Sr.MPEO / SDO(civil)	8000-13500	Asstt.Gen. Manager
				SDO(civil)
5.	6500-10500 6500-9900	A.E./ Shift Manager / Manager (Sale) / MPEO/ QCO / Store Officer / Purchase Officer/ FDO / Sr.MISO/ APO / AAO / Audit Officer	6500-10500	Manager
6.	5500-9000	Supdt./MISO/PA/Tech.Asstt. (Semen Bank)/ Sale Officer/ Sr.Accountant	5500-9000	Asstt. Manager
7.	5000-7850 5000-7100	Assistant/Stenographer / Accountant / Draftsman ((Mech) Sale Representative / Store Keeper/Coop. Inspector/ LSA(Semen Bank)	5000-7850	Executive Asstt.
		Draftsman (Civil)/ Junior Engineer(Civil)		Junior Engineer (Civil)

Chandigarh
Dated The

DEVENDER SINGH, IAS
MANAGING DIRECTOR

Endst. No: HDDCF: Admn/E-1/2006/Misc.218/ 115-90

Dated: 4/4/06

A copy is forwarded for information and necessary action to:-

-74-

3. including ACRs of all the employees covered under common cadre and the employees in the Pay scale of Rs. 6500-10500 from whom the promotion is to be made in the common cadre posts.
4. The Manager, SBTC, Rohtak
5. NOTICE BOARD

[Signature]
Chief Admn. Officer
For Managing Director

c.c.

All employees of HODCF at HPS, Panchkula

75

Cooperative Societies Haryana,
Chandigarh

To

The Managing Director,
HDDCF, Panchkula.

Sub: Approval of Staff Service Rules 1988.

Memo No. 1/1/07/MU/5552 Dated 30-5-07

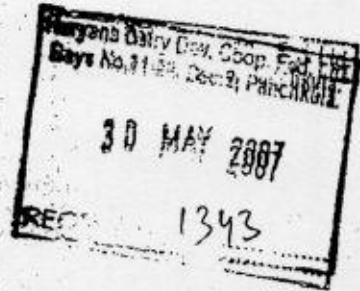

This is with reference to your letter No. HDDCF/Estt/2007/9573 dated 28-2-07 on the subject cited above.

The Staff Service Rules framed by Federation in the year 1988 are approved u/s 37 of the Haryana Cooperative Societies Act 1984 with the following amendments;

"The provision with regard to second appeal will be as under:-

	1 st appeal	2 nd appeal
In respect of employees of Union Cadre	BOD Milk Union	M.D. Dairy Federation
In respect of employees of Federation Cadre	BOD Federation	R.C.S.Haryana

30-5-07
CAO
30/5
A.M. Adani

31/5
AM
EA-2

Royal
Joint Registrar(Godown)
For Registrar, Cooperative Societies,
Haryana, Panchkula. *ln*

76

**HARYANA DAIRY DEVELOPMENT COOPERATIVE FEDERATION LTD.
BAYS NO. 21-22, SAHAKARITA BHAWAN, SECTOR-2, PANCHKULA**

Endst.No. EA-2/230/2007/ 2447-54 Dt. 20/10/07

A copy for information and strict compliance is forwarded to: -

1. All CEOs, Milk Unions in the State of Haryana.
2. General Manager, SBTC, Rohtak.
3. Asstt. Manager-I/Asstt. Manager-2 / Asstt. Manager-3 / Asstt. Manager-4
HDDCF Ltd., Panchkula;
4. Assistants in Estt. Br., HDDCF Ltd., Panchkula.

Chief Admn. Officer.
For Managing Director.

Report of the Anomaly Committee appointed to review the representations made in this behalf

The Committee had called the representations from all the employees of the Federation / Milk Unions. The Committee have considered all the representations and have made following recommendations:-

1. The post of DGM and AGM shall co-exist and filled up simultaneously.

In the approved organizational charts it has been provided that out of post of AGM in the pay scale of Rs. 8000-12500 and DGM in the pay scale of Rs. 10000-15200 only one post will be filled at a time. This condition has blocked elevation of Junior incumbents. Further the Mode of recruitment to the post of DGM is 100% by promotion out of the post of AGM whereas for AGM the mode of recruitment is 50% direct and 50% promotion. In the Organizational structure of Milk Unions and Federation there are 43 posts of AGM and 31 posts of DGM. Out of 43 posts of AGM 20 will come from direct recruitment and 23 by promotion. With this condition imposed few persons/incumbents of the post would be elevated to the higher post which results in blockage for the junior post to get elevated. To overcome the situation both the posts of AGM and DGM will co-exist and be filled up simultaneously. Further in order to provide more avenues to our own staff it is recommended that the condition of filling up of the post of AGM by 50% direct recruitment and 50% by promotion should be changed and the post of AGM be filled up by 25% direct

78

recruitment and 75% by promotion. This way there will be little financial liability as may be seen from the chart enclosed (sr.no.1 to 2).

2. Like above there is condition of recruitment on 50:50 basis to the post of Asstt. Manager, Executive Asstt., Lab. Asstt., Junior Mechanic, Plant Operator, Junior Store Keeper, Comp. Operator, Boiler Attendant. This condition is also depriving number of persons of promotion. It is recommended to change this condition to the extent that the posts mentioned above be filled up by 25% direct recruitment and 75% by promotion. It may be seen that with this condition 50 number of persons will get the chance of promotion. In turn there will be very little financial implication as may be seen from the chart enclosed (sr.no.3 to 10).

3. At present 103 clerks are working in the Milk Unions/Federation while as the sanctioned posts of clerks are 29. That means 74 Clerks are under diminishing cadre. We have 9 number of Class IV employees who are matriculates. They are already drawing higher pay scales. They are working in the organization for the last so many years. They even fulfill the qualification criteria laid down for promotion to the post of clerk. But since number of sanctioned posts of clerks are less, we are unable to promote them. To redress their grievances it is recommended that the persons who are matriculate be promoted to the post of clerk even if that post is under diminishing cadre. This will continue till all the persons who are matriculate are elevated to the post of clerk. However, promotion be effected only on the retirement of the employee/s from the post of clerk. Thus the number of clerks at any point of time, will not increase the existing strength of clerks. Further number of clerks to be promoted will also remain on diminishing cadre.

4. There is also a long pending demand from technical staff holding the post of Jr. Mechanic (Electr./Mech.) and compressor operators for which minimum educational qualification prescribed is Matric with IT Certificate/polytechnic for giving them the scale of Rs. 1200-2040 (unrevised) from 1.6.90 instead of Rs. 950-1500 and Rs. 4000-6000 instead of Rs. 3050-4590 from 1.1.1996 as prevalent in the Govt. departments. No. of employees in the above category are 26.

For such categories of staff working in Milk Unions it is recommended to grant them pay scale of Rs. 4000-6000. There will be little financial implication as may be seen from the chart enclosed. (sr. no. 11)

5. There are many posts available in the organizational chart which can not be filled from the feeding posts. It is proposed to fill such posts from other cadres. Presently Milk Unions do not have sufficient staff to look after the various activities of the Milk unions, efficiently and effectively. As per the approved Organizational Chart - Milk Union Sirsa has 3 vacant posts in Purchase Section viz Manager (Purchase), Asst Manager (Purchase), Executive Asst. (Purchase) but these posts have not been filled up. The work of the section is being looked after by the staff working in other sections in addition to the duties of the section where they are actually working. Similar is the situation in other sections of Milk Union Sirsa and also other Milk Unions.

It is recommended to change the cadre of all such employees those are working in section other than their original section. They may be promoted against the available vacant posts wherever feasible provided they have requisite experience ^{and qualifications} for the post. This exercise would motivate the employees to work better. For example if an employee of Accounts or Admn. section working in purchase section get his cadre

changed and is promoted against the vacant post available in purchase section then it will not only boost the morale of this employee to perform better but also other employees who will also get elevated to the post which will become vacant on the change of the cadre of the particular employee. By resorting to the above measure Unions will not have to induct the persons from the open market to fill up the vacant post and thereby incur additional financial liability.

*Employees belonging to technical cadre/section working in non-technical section would be adjusted there but not vice-versa. The feasibility to be verified by concerned Milk Unions/Federation at the level of Personnel Committee of Milk Union and MD of the Federation respectively.

6. The post of Exe. Asst.(Proc.) is to be filled up by 50% direct recruitment and 50% by promotion out of the category of DEW having 5 years experience as DEW. No further recruitment is to be made to the post of DEW. 50:50 ratio will be maintained till DEWs are promoted to the post of Exe. Asst.(Proc.). Thereafter recruitment to the post of Exe. Asst.(Proc.) will be 100% direct. The work of both the posts DEW and EA(Proc.) is similar. It is recommended to convert maximum no. of DEWs as EA(Proc.). To achieve this it is further recommended that the post of EA(Proc.) be filled by 25% direct recruitment and 75% by promotion.
7. Number of posts of AM (PA) in the HDDCF be increased from existing 2 to 7 so that all the Divisional Heads may be provided one PA in the payscale of Rs.5500-9000. This is being recommended in view of the increased status of the Divisional Heads. They will be provided to Chairman HDDCF and other Divisional Heads as under:

Chairman

-1

- Chief Admn. Officer	-1
- General Manager(A&F)	-1
- General Manager(P&M)	-1
- General Manager(P&T)	-1
- Sr. Functionaries being taken on contract for Milk Procurement	-1
- Milk Marketing activities.	-1

	7

With this the no. of sanctioned posts of Exe. Asst. (Stenographer) will reduce from 7 to 5.

Stenographers will be provided to other officers as under:

- Executive Engineer(civil)	1
- AGM(Quality Control)	1
- AGM(MIS)	1
- Manager(Admn)	1
- Manager(Accls)	1

Total	5

Financial liability on account of increasing the strength of AM(PA) may be seen from the chart, enclosed (sr.no. 12)

8 In case of Milk Union the post of stenographer in the pay scale of Rs. 5000-7850 has been clubbed with Executive Asst.(Admn). The same need to be delinked from the Admn. branch and shown as separate cadre as has been done in case of Federation. To provide promotional avenues to the staff, one post of Asst.Mgr.(PA) in the pay scale of Rs. 5500-9000 need to be provided in each milk union in addition to 1 post of Executive Asstt. (Stenographer) in each Milk Union.

This is being recommended in view of the increased status of the Chief Executive Officer of Milk Unions. The post of CEO/GM of the Milk Union, has been upgraded from the pay scale of Rs. 10000-15200 to 13500-17200.

The post of Executive Asstt.(Stenographer) and Asstt.Mgr.(PA) will be filled up as under:

82

Executive Asstt.(Stenographer) Promotion= 100%

Out of category of Steno typist having 7 years experience as steno typist.

Asstt.Mgr.(PA)

Promotion= 100%
Out of category of Executive Asstt.(Stenographer) having 5 years experience as Executive Asstt.(Stenographer)

Financial liability on account of increasing the strength of AM(PA) may be seen from the chart enclosed(sr.no. 13)

9. Experience of 15 years has been fixed for promotion to the post of SDO (Civil) in the pay scale of Rs. 8000-13500 from the post of Junior Engineer (Civil)/D.M. in the pay scale of Rs. 5000-7850. In Govt. Deptts. whenever any post of SDO (Civil) becomes vacant Junior Engineer(Civil) is immediately promoted on seniority basis without asking for his practical experience. Earlier in the Staff Service Rules the experience of 10 years was fixed instead of 15 years for promotion to the post of SDO (Civil) from the post of Junior Engineer (Civil)/DM(already designated as JE(Civil)). Keeping in view the above, it is proposed that the experience required for promotion to the post of SDO (Civil) be reduced from 15 years to 10 years.

Earlier both the posts of SDO (Civil) were filled up by direct recruitment.

Now both these posts will be filled up by promotion.

10. In case of Milk Procurement Section some conditions as enumerated below have been laid down for creation of posts/ promotion to the higher posts viz Executive Asstt.(Proc.), Asstt.Manager, Manager(Proc.) Asstt.General Manager, Dy.General Manager.

83

One Executive Asst(Proc.) will be posted against 25 functional societies (average for the year.) After increase of every 25 functional socs, one additional post of EA(Proc) be created.

One AM(Proc) will be posted against 150 societies (average for the year)

One Mgr.(Proc) will be posted against 400 societies(average for the year).

Promotion to the higher post from EQ(Proc) to the post of DGM(P&I) will be made when besides fulfilling functional societies criteria the milk procurement of the union in terms of average milk procurement/society/day is equivalent to the State average milk procurement/society/day. The figure of the union will be compared with the average of the last 3 years of the State as a whole.

The average milk proc. /society /day for 2005-06 was 77kgs. In respect of Milk Union, Ambala, 108 kgs- M.U.Hisar-Jind, 68 Kgs.- M.U. Kurukshetra-Karnal, 103kgs.-M.U.Rohtak, 114kgs.- M.U. Ballabgarh, 103kgs.-M.U.Sirsa and 98 kgs. for the state as whole. Thus from the above it is evident that employees working in Milk Union, Ambala and Kurukshetra-Karnal can not be elevated to higher posts as the ave. milk proc./society/day in case of M.U. Ambala and Kurukshetra-Karnal is lower than the State average of 98 kgs. The situation is the same in these milk unions for the previous years also. At any point of time when we will compare the average milk procurement/society /day of the union with the state average, there will always be a situation when some unions will fail to meet the state average.

At the same time against the milk procurement target of 48000 kgs./day laid down for the year 2005-06, M.U.Ambala has procured on an average 48,200 kgs./day and M.U. Kurukshetra-karnal against the target of 26000 kgs./day has procured on an

-8-
average 32,100 kgs./day . The achievement of these milk unions otherwise is noteworthy.

But with the above condition in vogue the employees of these Milk Unions in Milk procurement section can not be promoted. No such condition has been laid down for promotion to higher posts in other sections. Accordingly it is recommended that the above condition of milk procurement and functional societies be waived for effecting promotion in Procurement Section to the extent that MD HDDCF should satisfy himself that Milk Union/s which have not been able to achieve the above condition have otherwise performed well w.r.t. the targets laid down in terms of Functional Societies/Milk Procurement. Further if there was some adverse situation/factors beyond the control of the milk union as a result of which union could not meet/achieve the conditions/targets laid down, MD HDDCF may further satisfy himself before allowing milk union to promote staff in Milk Procurement section.

However, for creation of post of E.A(Proc.), A.M(Proc.) and Mgr.(Proc.), the criteria of functional societies as given above will continue as such.

11. Sh.O.P.Sawhney was elevated to the post of Manager (Admn.) in the pay scale of Rs.6500-10500 from the post of AM(Admn.) in the pay scale of Rs.5500-9000 during April,06. Prior to his promotion he was drawing a basic pay of Rs.10400/-. His pay now can not be fixed after giving him the benefit of one increment of Rs.200/- under Rule 32.1 of Haryana Staff Service Rules,1988 as the last basic pay of the scale is Rs.10500/- only.

If he would have continued to work on the post of AM(Admit.) in the pay scale of Rs.5500-9000 his pay would have been fixed at Rs.10575/-. His pay is now going to be reduced in the promoted rank of Manager(Admn). Further his retirement benefits will also get reduced at the time of his retirement. To avoid any financial loss to him at the verge of his retirement on 31.10.2006, his basic pay may be fixed as Rs.10600/- as a special case and this will remain a personal measure to him.

12. Sh.K.C.Batra, was promoted to the rank of Manager(Private Secretary) in the pay scale of Rs.8500-10800 from the post of AM(PA) in the pay scale of Rs.5500-9000 during April,06. Prior to his promotion he was getting a special pay of Rs.150/- and conveyance allowance of Rs.150/- which on his elevation to the post of Manager(PB) has been withdrawn, which is a direct financial loss to him. To compensate him it is proposed to grant him a special pay of Rs. 150/- and conveyance allowance of Rs.150/- which he was drawing previously on the post of AM(PA), as a special case, and this will remain a personal measure to him.

13. To provide promotional avenues to the personnel working in Production, quality control & engineering sections no. of hierarchical levels have been provided in the organizational chart of Milk Unions/Federation. For all those employees who possess the requisite qualification there is no restriction for them to get elevated to the rank of General Manager in the pay scale of Rs.13500-17250 and even Chief General Manger in the pay scale of Rs. 18400-22400. However in case of Civil Engineering Section one

86

-10-

can only go upto the post of Executive Engineer -civil in the
pay scale of Rs. 10000-15200.

To remove the stagnation it is recommended that next functional
pay scale of Rs. 13500-17250 be granted to the incumbent of the
post of Executive Engineer (civil) after 5 years of regular
satisfactory service as Executive Engineer (civil).

Some more representations have been received from the Milk Unions
for increasing the no. of sanctioned posts in various categories of
posts.

The Committee has gone through the same and observed that the
requirement of staff varies from Union to Union. In the revised
Organizational Charts of Milk Union, by and large, a uniform pattern has
been followed while sanctioning the posts. The committee will hold
meeting with CEO's of milk unions and have detailed discussions with
them and other senior functionaries before recommending any further
increase in the no. of posts. It is all the more necessary to undertake
this exercise as it is not long since the last revision of the
organizational charts was carried out.

The Committee will submit its recommendations on the above in due
course of time

Matter is placed before the Board of Directors for consideration and
approval of the following decisions:-

The revised organizational charts of Milk Unions and Federation along
with revised qualifications and mode of recruitment be further amended
to the above extent. These will come into force from the date these are
approved by the Registrar Cooperative Societies, Haryana.

A Chart showing financial liability of the posts to be filled up after removal of condition laid down in revised organizational Chart of Mus.Fed.

Sr.No.	Post	Present Payscale(Rs.)	No. of Posts to be filled prior to removal of conditions as laid down in the organisational charts		No. of Posts to be filled after removal of all conditions i.e. filling up both the posts of AGM & DGM and 75% Promotion	No. of Posts to be filled up for which additional financial liability will have to be incurred	Financial Liability/Month (Rs.)
			1	2			
					3	4=(3-1)	5
			Direct(50%)	Promotion(50%)			
1	DGM	10000-15200		8(100%)	31	23	13915
2	AGM	8000-13500	20	23	33	10	5120
3	Asst Manager	5500-9000	21	24	35	11	3580
4	Exe. Asst	5000-7850	17	17	26	9	2511
5	Lab.Asst	3050-4590	13	16	23	7	847
6	Jr. Mech(Engg.)	3050-4590	1	1	2	1	121
7	Plant Operator	3050-4590	2	4	5	1	121
8	Junior Store Keeper	3050-4590	15	16	24	8	968
9	Compressor Operator	3050-4590	3	5	7	2	242
10	Boiler Attendant	3050-4590	1	3	4	1	121
11	Junior Mech(Electr)Mechly Compressor Operator	3050-4590	(Post to be upgraded in the pay scale of Rs. 4000-5000)		26	26	4636
12	Asst. Manager(PA)-Fed.	5500-9000				5	1625
13	Asst. Manager(PA)-MU	5500-9000				6	1932
	Total					Annual	431520
							35958

To consider the request of the employees for removal of stagnation.

The New organizational charts approved by the Board of Directors and subsequent approval of the same with certain amendments by RCS in respect of the charts of the Federation and comm. on cadre employees has been implemented. There is resentment amongst the staff who are held up on the same post for more than 20 - 30 years and see no scope for promotion / removal of stagnation.

To alleviate this genuine grievance of the stagnated employees the following proposal has been worked out: -

1. Any person holding a post for 20 years or more as on 1.4.2006 in the same pay scale will get next promotional pay scale and post and these will be personal to these persons. This procedure will continue in future also.
2. If any employee is getting an ACP scale which does not correspond with the scales provided in the organizational chart, & have completed 20 years on the same post, the person will be placed in the scale as per organizational charts
3. If any employee who is already getting promotional scale by virtue of his placement through ACP Pay scale without change of any designation, in that event the concerned employee will automatically be re-designated as per the organizational chart.
4. There are 139 numbers of employees of the all the Milk Unions and the Federation who will stand benefited.
5. The financial liability works out to about Rs. 88,000/- P.M. only. The unit wise details are enclosed with the agenda. (Annexure)

In view of the position explained above, it will be seen that by implementing the above decision, a large number of employees will be motivated and feel elevated to the next scale which will boost the morale of these employees.

Further more, it is relevant to add here that the financial liability on this account only will be 0.02% of the total turn over of the organization.

89

There are cases where Govt. of Haryana have also provided incentive to some categories based on number of years of service put in e.g. :

Dairy Development	Distt. Dairy Development Officer	i) 8000-13500 ii) 10000-13900 (After 5 years of regular satisfactory service in the Cadre) iii) 12000-16500 (After 11 years of regular satisfactory service in the Cadre). The above scales shall be applicable with effect from 13.2.96 and shall have strict linkages with the qualifications and parties with the Animal Husbandry department.
PWD (PH) (B&R) (Irrigation)	A.E.E / A.E. / S.D.Es.	i) 8000-13500 ii) 10000-13900 (After 5 years of regular satisfactory service in the Cadre) iii) 12000-16500 (After 11 years of regular satisfactory service in the Cadre). It is certified that for the grant of the second ACP scale of 12000-16500, 20% of the posts in the Cadre of SDEs / AEs / AEEs will be considered. As soon as an officer (SDE/AE/AEE) gets promoted as XEN, the slot reserved under 20% will be vacated by him.

Matter is placed before the Board of Directors for consideration and approval.

(ANNEXURE)

UNIT-WISE DETAIL OF FINANCIAL LIABILITY (P. MONTH)

SR NO.	NAME OF THE UNIT	NO OF EMPLOYEES	AMOUNT (RS)
1	HDDCF LTD	13	5758
2	MILK UNION ROHTAK	44	24128
3	MILK UNION AMBALA	22	14707
4	MILK UNION JIND	34	18882
5	MILK UNION SIRSA	10	3386
6	MILK UNION BALLABGARH	14	10788
7	MILK UNION KURUKESHTRA	2	930
8	TOTAL	139	78579
9	EMPLOYER SHARE (PF)@12%		9430
10	TOTAL LIABILITY	139	88009

91

KBCFLTD

Name	Post	Present Scale	Date in this scale	Length Of Service in year	Proposed Scale	Present Basic	Proposed Basic	Diff	Financial Liability
S.SH.SMT.									
Kushai Mari	Steno	5000-7850	1981	25	5500-9000	7700	7950	250	465
Ganesh Dutt	Steno	5000-7850	1981	25	5500-9000	7700	7950	250	465
Sucesh	Steno	5000-7850	1981	25	5500-9000	7550	7775	225	418
Priyam Chand	Clerk	3050-4590	1982	24	5000-7850	4670	5000	330	614
Mangleshwar	Driver	5450-8000	-	-	5500-9000	6950	7075	125	233
Jasbir Singh	Driver	5450-8000	-	-	5500-9000	6950	7075	125	233
Hari Chand	Driver	5450-8000	-	-	5500-9000	6950	7075	125	233
R.K. Gupta	AAO	6500-10500	1985	21	8000-13500	10100	10475	375	698
N.P. Gupta	Acctt	5000-7850	1979	27	5500-9000	8300	8475	175	326
Surinder Mohan	Acctt	5000-7850	1985	21	5500-9000	7700	7950	250	465
Inder Mohan	Steno	5000-7850	1984	22	5500-9000	7550	7775	225	418
Gulshan Ahuja	Asstt	5000-7850	1980	26	5500-9000	8150	8300	150	279
Gobind Singh	Clerk	3050-4590	1981	25	5000-7850	4510	5000	490	911
							Total:		5758

92

MILK UNION
ATAK

Financial Implication on grant of promotional scale to employees completed 10 yrs regular service & got no ACP scale/promotion at MU Rohlak

Sr. No.	Name	Designation	Scale of post	Date of drawing the present scale	Length of service at present scale	Promotional scale on completion 10 yrs	Basic pay drawing on 1.1.2006	Pay to be fixed on promotional scale	Difference of basic pay	Total Addl. Liability Rs.
1	D.S. Nawat	Manager (Proc)	6500-10500		20 years	7500-13500	10900	11025	125	233
2	Ramu Hooda	Manager (Mktg)	6500-10500	10.02.1984	22 years	7500-13500	10900	11025	125	233
3	R.K. Bhardwaj	M (Mktg)	6500-10500	24.09.1982	23 years	7500-13500	10900	11025	125	233
4	Y.V. Singh	M (Input)	6500-10500	18.06.1979	26 years	7500-13500	10500	10750	250	465
5	S.S. Malik	A. M (Proc)	5500-9000	03.05.1977	29 years	6500-10500	10825	11100	275	326
6	M.D. Ahuja	A. M (Proc)	5500-9000	08.09.1982	23 years	6500-10500	9825	9700	125	326
7	R.P. Guhani	A. M (Proc)	5500-9000	06.09.1982	23 years	6500-10500	9525	9700	175	326
8	K.K. Sharma	A. M (Proc)	5500-9000	12.03.1985	21 years	6500-10500	9525	9700	175	326
9	J.S. Yadav	A. M (Proc)	5500-9000	11.03.1985	21 years	6500-10500	9525	9700	175	326
10	R.A. Yadav	A. M (Proc)	5500-9000	08.03.1985	21 years	6500-10500	9700	9900	200	372
11	Shamsher Singh	E.A. (Adm)	5000-7850	12.12.1977	28 years	6500-10500	7850	8125	275	512
12	S.V. Sharma	E.A. (Adm)	5000-7850	13.08.1974	31 years	6500-10500	8750	9000	250	465
13	G.K. Bhandula	E.A. (Steno)	5000-7850	05.01.1983	23 years	6500-10500	7700	7950	250	465
14	Kashmiri Lal	EA (Accounts)	5000-7850	20.12.1985	20 years	6500-10500	7700	7950	250	465
15	Suraj Mal	EA (Proc)	5000-7850	01.04.1985	21 years	6500-10500	7850	8125	275	512
16	Suraj Bhan	EA (Proc)	5000-7850	18.04.1985	21 years	6500-10500	7850	8125	275	512
17	Bal Mukand	EA (Proc)	5000-7850	01.07.1979	26 years	6500-10500	7100	7250	150	279
18	Purshiam Dass	EA (Proc)	5000-7850	01.07.1979	26 years	6500-10500	7700	7950	250	465
19	Kapoor Singh	EA (Proc)	5000-7850	01.07.1979	26 years	6500-10500	7850	8125	275	512
20	Gajnder Singh	EA (Proc)	5000-7850	01.07.1979	26 years	6500-10500	7850	8125	275	512
21	R. S. Rohila	EA (Proc)	5000-7850	01.07.1979	26 years	6500-10500	7850	8125	275	512
22	Itwar Singh	EA (Proc)	5000-7850	01.07.1979	26 years	6500-10500	7550	7775	225	419

-34-

93 -M-

23	Ajit Singh	Time keeper	1400-6000	01.04.1980	25 years	5500-9000	6950	7075	125	233
24	Raj Singh	Time keeper	4000-6000	19.01.1983	23 years	5500-9000	6800	6900	160	186
25	Hukam Singh	Driver	4000-6000	15.12.1976	29 years	3500-9000	6850	7075	125	233
26	Rajinder Singh	Driver	4000-6000	04.07.1985	20 years	5500-9000	5900	6900	100	186
27	Mitya Nand	Driver	4000-6000	01.09.1977	28 years	5500-9000	6950	7075	125	233
28	Mahaveer Singh	Driver	4000-6000	01.03.1978	27 years	5500-9000	6950	7075	125	233
27	Ram Mehar	Driver	4000-6000	26.06.1985	29 years	5500-9000	6800	6900	100	186
28	Fateh Singh	Driver	4000-6000	01.03.1986	20 years	5500-9000	6850	6725	75	140
29	Krishan Singh	Driver	4000-6000	29.10.1985	20 years	5500-9000	6800	6900	100	186
30	Suleth Chand	Plant Operator	3050-4590	14.11.1985	20 years	5000-7850	4510	5000	490	911
31	Mam Rai	Plant Operator	3050-4590	14.11.1985	20 years	5000-7850	4510	5000	490	911
32	Hambai Kaushik	Plant Operator	3050-4590	14.11.1985	20 years	5000-7850	4510	5000	490	911
33	Rajinder Kumar	Plant Operator	3050-4590	14.11.1985	20 years	5000-7850	4510	5000	490	911
34	Satbir Singh	Plant Operator	3050-4590	14.11.1985	20 years	5000-7850	4510	5000	490	911
35	Ram Phal	Plant Operator	3050-4590	14.11.1985	20 years	5000-7850	4510	5000	490	911
36	Rajbir Singh	Plant Operator	3050-4590	14.11.1985	20 years	5000-7850	4510	5000	490	911
37	Jagdish Parshad	Plant Operator	3050-4590	14.11.1985	20 years	5000-7850	4510	5000	490	911
38	Ishwar Singh	Plant Operator	3050-4590	14.11.1985	20 years	5000-7850	4510	5000	490	911
39	Madan Lal	Plant Operator	3050-4590	14.11.1985	20 years	5000-7850	4510	5000	490	911
40	Jai Bhagwan	Plant Operator	3050-4590	14.11.1985	20 years	5000-7850	4510	5000	490	911
41	Bishamber Singh	Plant Operator	3050-4590	14.11.1985	20 years	5000-7850	4510	5000	490	911
42	Krishan Kumar	Plant Operator	3050-4590	14.11.1985	20 years	5000-7850	4510	5000	490	911
43	Mathu Ram	Plant Operator	3050-4590	14.11.1985	20 years	5000-7850	4510	5000	490	911
44	Chet Ram	Clerk	3050-4590	01.01.1991	25 years	5000-7850	4590	5000	410	762
									12670	24128

94

Milk union Ambala

Detail of promotional benefit after 20 year

Sr	Name	Desig.	Present scale	Basic As on 1.4.06	Date of present scale	Length of service	promotional scale after 20	perposed Basic	Benefit
1	Sh. M. P. Singh	Acctt.	5000-7850	7700	23.12.81	25	5500-9000	7550	465
2	Sh. Gobind Singh	Cook	3050-4590	4990	1.3.77	29	5000-7850	5150	298
3	Sh. Jilwer Mashi	P.D.	3050-4590	4590	28.8.85	20	5000-7850	5050	763
4	Sh. Jagjit Singh	P.D.	3050-4590	4590	28.8.85	20	5000-7850	5050	763
5	Sh. Gurdev Singh	P.D.	3050-4590	4590	28.8.85	20	5000-7850	5050	763
6	Sh. S. S. Saini	M/A/C	6500-9900	10100	1.3.85	21	8000-13500	10475	693
7	Sh. Jaspal	M/Prod.	6500-10500	10300	1.7.85	20	8000-13500	10750	827
8	Sh. I. K. Tenja	M/Prod.	6500-10500	10500	1.9.85	20	8000-13500	10750	855
9	Sh. Baldev Singh	P.O.	3050-4590	4590	14.11.85	20	5000-7850	5000	763
10	Sh. Mangal Singh	P.O.	3050-4590	4590	14.11.85	20	5000-7850	5000	763
11	Sh. Nand Lal	P.O.	3050-4590	4430	14.11.85	20	5000-7850	5000	1050
12	Sh. Jagir Singh	P.O.	3050-4590	4430	14.11.85	20	5000-7850	5000	1050
13	Sh. Manglu Ram	P.O.	3050-4590	4430	14.11.85	20	5000-7850	5000	1050
14	Sh. Jai Parkash	P.O.	3050-4590	4350	14.11.85	20	5000-7850	5000	1050
15	Sh. Devendar Singh	Lab. Attnd.	2650-4000	3440	18.1.83	23	3050-4590	3575	252
16	Sh. S. S. Sharma	Acctt.	5000-7850	6150	27.6.80	26	5500-9000	8300	279
17	Sh. Shashi Mohan	S/Rep.	5000-7850	7400	2.1.86	20	5500-9000	7600	372
18	Sh. Rajinder Sharma	EA Admn	5000-7850	7850	3.7.79	26	5500-9000	8125	512
19	Sh. Kuljit Singh	Agm (proc)	8000-13500	13500	1.7.85	20	10000-15200	13900	724
20	Sh. Rajpal Singh	M(Input)	6500-10500	10300	1.7.85	20	8000-13500	10750	637
21	Sh. Sultan Singh	EA (Proc)	5000-7850	7100	17.3.80	26	5500-9000	7250	279
22	Sh. K. K. Gupta	EA Acctt.	5000-7850	7700	1.1.84	22	5500-9000	7650	465
							Total		14707

-35-

- 95

The H. S. Jind Co. Mills Road. Union Hotel Mills Kant Jind

Sr No	Name Of Employee	Designation	Present Scale of the Post	Date of Joining on Present Post	Basic Pay as on 1-4-06	Length of service after 20 year	Permoational scale after 20 year	Proposed BP in Prompted Scale	Financial Liability
1	SH GULSHAN KUMAR	EA(Accts)	5000-7850	23.12.1981	7700.00	24	5500-9000	7950	465
2	SH K.R. JINDAL	EA (Admn)	5000-7850	18.7.1979	7850.00	26	5500-9000	8125	512
3	SH RAM KUMAR	SWEOPER	2550-3200	16.4.1973	3320.00	33	3050-4530	3425	195
4	SH LOKESH KUMAR CHOPRA	EA (Proc)	5000-7850	1.4.1985	7850.00	21	5500-9000	8125	512
5	SH ASHOK KUMAR	COMP.OP	3050-4590	19.1.1979	4590.00	27	5000-7850	5000	762
6	SH OM PARKASH	COMP.OP	3050-4590	14.11.1985	4510.00	20	5000-7850	5000	911
7	SH OM PARKASH	EA(Q.C.)	5000-7850	8.8.1985	7850.00	20	5500-9000	7950	186
8	SH MOHINDER SINGH	L.ASST	3050-4590	7.2.1980	5310.00	26	5000-7850	5450	260
9	SH OM SINGH	EA (Proc)	5000-7850	1.4.1985	7850.00	21	5500-9000	7950	186
10	SH MASTAN CHAND	P.O.P	3050-4590	14.11.1985	4430.00	20	5000-7850	5000	1060
11	SH RA-MESH KUMAR-11	P.O.P	3050-4590	14.11.1985	4510.00	20	5000-7850	5000	911
12	SH TEK RAM	P.O.P	3050-4590	14.11.1985	4510.00	20	5000-7850	5000	911
13	SH RAGHUBIR SINGH	P.O.P	3050-4590	8.11.1985	4510.00	20	5000-7850	5000	911
14	SH SUBASH CHANDER	P.O.P	3050-4590	8.11.1985	4510.00	20	5000-7850	5000	911
15	SH VISHNU DEV MANDAL	P.O.P	3050-4590	14.11.1985	4590.00	20	5000-7850	5000	762
16	SH MAHABIR SINGH	P.O.P	3050-4590	14.11.1985	4510.00	20	5000-7850	5000	911
17	SH LAKHI RAM	P.O.P	3050-4590	16.11.1985	4510.00	20	5000-7850	5000	911
18	SH PALA RAM	P.O.P	3050-4590	8.11.1985	4510.00	20	5000-7850	5000	911
19	SH KARAN SINGH-11	P.O.P	3050-4590	14.11.1985	4510.00	20	5000-7850	5000	911
20	SH RADHEY SHYAM	EA (Proc)	5000-7850	1.4.1985	7700.00	20	5500-9000	7950	455
21	SH ISHER DASS	EA (Proc)	5000-7850	21.5.1960	7100.00	26	5500-9000	7250	279
22	SH NIHAL SINGH	EA (Proc)	5000-7850	18.3.1980	8300.00	26	5500-9000	8475	326
23	SH RAM KUMAR CHAUHAN	DEW	3050-4590	12.12.1977	4990.00	28	5000-7850	5000	19
24	SH R.E. MALIK	EA (Proc)	5000-7850	17.5.1980	8300.00	26	5500-9000	8475	326
25	SH BHOOP SINGH	EA (Proc)	5000-7850	1.2.1985	7100.00	18	5500-9000	7250	279
26	SH R.K. DALAL	EA (Proc)	5000-7850	1.2.1988	6650.00	18	5500-9000	6950	465
27	SH JAGBIR SINGH MALIK	EA (Q.C)	5000-7850	23.7.1985	7250.00	20	5500-9000	7425	325

36

96

- 22

Sr No	Name Of Employee	Designation	Present Scale of the Post	Date of Joining on Present Post	Basic Pay as on 1-4-06	Length of service	Permoational scale after 20 year	Proposed BP in Prompted Scale	Financial Liability
36	SH DILBAG SINGH	EA (Proc)	5000-7850	1.4.1985	7850.00	21	5500-9000	8125	511
37	SH RAM KUMAR SHARMA-1	EA (Proc)	5000-7850	3.5.1985	6950.00	21	5500-9000	7250	558
38	SH SUBE SINGH	EA (Proc)	5000-7850	14.3.1980	8300.00	26	5500-9000	8475	326
39	SH AMRIT LAL	EA (Proc)	5000-7850	1.4.1985	7700.60	21	5500-9000	7950	465
40	SH SHIVPAL VERMA	EA (Proc)	5000-7850	1.4.1985	7850.00	21	5500-9000	8125	511
41	SH RAM PHAL SHARMA	EA Proc	5000-7850	8.3.1979	8750.00	27	5500-9000	9000	465
42	SH MANPHOOL SINGH	EA (Proc)	5000-7850	24.12.1979	8750.00	26	5500-9000	9000	465
Total 54									18882

97

THE SIRSA DISST. MILK UNION SIRSA
PROPOSED STEP UP TO 20 YEARS SERVICE

S.No	Name Of Employee	Designation	Basic Pay	Present Scale	Scale of post	Post Holding w.e.f.	Yrs Completed on this post	1st promi. scale	Present Basic	Proposed Basic in Next Scale	Benefit	Financial implementation.
1	BHOLA SINGH	WATCH MAN	3440	Rs 2650-65-4000	Rs 2610-60-3540	26.6.85	20	Rs 3050-75-4590	3440	3575	135	250
2	MOHINDER LAL	DRIVER	6650	Rs. 5400-150-8000	Rs 4000-100-6000	26.6.85	20	Rs 5000-150-7850	6650	6725	75	140
3	NARAIAN SINGH	PEON	3200	Rs 2550-60-3200	Rs 2550-60-3200	26.6.85	20	Rs 3050-75-4590	3200	3275	75	140
4	IRAM BAHADUR	WATCH MAN	3440	Rs 2650-65-4000	Rs 2610-60-3540	26.6.85	20	Rs 3050-75-4590	3440	3575	135	250
5	NAFE SINGH	A.M.P.O	9525	Rs 5500-175-9000	Rs 5500-175-9000	3.1.84	22	Rs 6500-200-10500	9525	9700	175	326
6	IRAM KUMAR	DAIRY MAN	3300	Rs 2650-65-4000	Rs 2650-65-4000	1.4.83	23	Rs 3050-75-4590	3300	3425	125	233
7	AN MEHTA	Acct.	6950	Rs 5000-150-7850	Rs 5000-150-7850	21.8.81	24	Rs 5500-175-9500	6950	7250	300	558
8	RAM KUMAR BISHONOI	E.M.P.A	8300	Rs 5000-150-7850	Rs 5000-150-7850	10.8.81	24	Rs 5500-175-9500	8300	8475	175	326
9	S. BALLYAN	F.D.O.	10300	Rs 6500-200-10500	Rs 6500-200-10500	80	25	Rs 8000-275-13500	10300	10750	450	837
10	S. K. YADAV	E.M.P.A	9175	Rs 5000-150-7850	Rs 5000-150-7850	7.6.77	28	Rs 5500-175-9000	9175	9350	175	326
											1820	3386

256

98

21-

THE BALLABGARH CO-OPERATIVE MILK PRODUCERS UNION LTD : MILK PLANT BALLABGARH
Financial liabilities

Sl. No.	NAME	FNAME	Present DEG	Present Scale	BP As on 1.4.06	DP	DA	TOTAL	Date of the Present Scale	L.O.S. in the present scale	Pay Scale after 20 yrs	Basic Pay in the Promoted scale	D.P.	D.A.	Total
1	Y. K. RA	SH. S. L. KALRA	MGR. O	5500-10500	11100	5550	3956	20646	17.7.1979	26	8000-13500	11300	5650	4068	21018
2	H. C. DOGRA	SH. JODHA DOGRA	MGR. P	6500-10500	11500	5750	4140	21390			8000-13500	11850	5525	4266	22041
3	J. M. CHADHA	SH. R. P. CHADHA	MGR. P	6500-10500	11500	5750	4140	21390			8000-13500	11850	5525	4266	22041
4	J. S. CHANDEL	SH. M. L. CHANDEL	AE	6500-10500	10900	5450	3924	20274			8000-13500	11300	5650	4068	21018
5	K. P. UPADHAYAY	SH. K. P. UPADHAYAY	MGR. P	6500-10500	9500	4750	3420	17670			8000-13500	9925	4553	3573	18451
6	K. S. SHARMA	SH. SHIV RAM SHARMA	MGR. P	6500-10500	11500	5750	4140	21390			8000-13500	11850	5525	4266	22041
8	SAROJ KUMAR GUPTA	Sr. Tara Chand	MGR. P	6500-10500	11500	5750	4140	21390			8000-13500	11850	5525	4266	22041
9	SUNIL SRIVASTVA	SH. V. N. SRIVASTVA	MGR. I	6500-10500	10100	5050	3636	18786			8000-13500	10300	5555	3705	19123
10	S. S. YADAV	SH. P. D. YADAV	AM. P	5500-9000	10925	5463	3933	20321	6.5.1978	28	6500-10500	11100	5555	3996	20646
11	PREM LAL	SH. TANGI LAL	P. O.	3050-4590	4350	2175	1566	8091	27.5.1986		205000-7850	5000	2555	1800	9300
12	RAM CHANDER	SH. BHARAT RAM	P. O.	3050-4590	4350	2175	1566	8091	27.5.1986		205000-7850	5000	2555	1800	9300
13	RATAN SINGH	SH. GIROHARI LAL	LAST	3050-4590	3950	1975	1422	7347	14.12.1985		205000-7850	5000	2500	1800	9300
14	SUKHPAL	SH. BHULE RAM	P. O.	3050-4590	4350	2175	1566	8091	27.3.1986		205000-7850	5000	2500	1800	9300
	TOTAL				115525	57763	41589	214877				121325	60663	43677	225665
										Diff					10782.00

59

99

THE KURUKESHTRA MILK PRODUCERS UNION LTD KURUKESHTRA.

SR NO	NAME	POST	PRESENT		DATE IN THE YRS SCALE	NO OF PRESENT		PROPOSED		PROPOSED FINANCIAL	
			PAY-SCALE			THEYRS	BASIC	SCALE	BASIC	LIABILITY	
1	SH. B. M. GOEL	Sr. ACCT	5500-9000		13.9.85	21	9000	6500-10500	9300	558	
2	SH. S. K. SAINI	FDO	6500-9900		19.12.81	24	11100	8000-13500	11300	372	
										930	

100



EPABX Nos: 2586487, 2585513
 Email : vita@satyam.net.in
 Fax No : 2587527
 Telegram : VITALITY

HARYANA DAIRY DEVELOPMENT COOPERATIVE FEDERATION LTD
BAYS NO. 21-22, SAHAKARITA BHAWAN, SECTOR-2, PANCHKULA

An Extract from the proceedings of 142nd meeting of the Board of Directors of Haryana Dairy Development C-operative Federation Ltd. held on 26th June, 2006 at Bays No. 21-22, Sahakarita Bhawan, Sector-2, Panchkula.

06/142/2006	Report of the Anomaly Committee appointed to review the representations made in this behalf.	The matter was approved in principle. On promotion the pay of Sh. K.C. Batra, Manager (Private Secy.) and Sh. O.P. Sawhney, Manager(Admn) be protected. However, recommendations of Anomalies Committee and observations of BOD be implemented only after the approval of the RCS and in case of Mr. K. C. Batra, if PS is entitled to special pay / allowance in Haryana Govt., same be accorded to him. Nominee of Finance Deptt. Sh. Kulwinder Singh wanted to place on record FD's observation that the proposal would require approval of FD.
-------------	--	--

Endst. No. BOD:142:2006: 13511 Dt. 1/8/06

A copy is forwarded to A.M.-II (Admn) for information and necessary action.

He is requested to intimate the action taken on the proceedings within a period of 15 days positively.

(Signature)
 Manager(Admn.)
 For Managing Director



EPABX Nos: 2586487, 2585513
 Email : vita@satyam.net.in
 Fax No : 2587527
 Telegram : VIHALIY

HARYANA DAIRY DEVELOPMENT COOPERATIVE FEDERATION LTD
BAYS NO. 21-22, SAHAKARITA BHAWAN, SECTOR-2, PANCHKULA

An Extract from the proceedings of 142nd meeting of the Board of Directors of Haryana Dairy Development C-operative Federation Ltd. held on 26th June, 2006 at Bays No. 21-22, Sahakarita Bhawan, Sector-2, Panchkula.

7/142/2006	To consider the request of the employees for removal of stagnation.	The approval was granted in principle. However, before implementation the approval of RCS be obtained. Nominee of Finance Deptt. Sh. Kulwinder Singh wanted to place on record FD's observation that the proposal would require approval of FD.
------------	---	---

Endst. No. BOD:142:2006: 3512

DL 1/8/06

A copy is forwarded to

AM-II Admin

for

He is requested to intimate the action taken on the proceedings within a period of 15 days positively.

[Signature]
 Manager (Admin.)
 For Managing Director.

102

H.D.D.C.F.
B.O.D.

Agenda Item No. 10/144/2007

Page No. 28

Sub: Promotion avenues to the group 'C' & 'D' employees on the posts of Drivers.

As per revised Organizational chart of the Federation, the qualification and experience to the post of Driver in the Scale of Rs. 4000-6000 is as follows: -

Promotion: Nil

Direct : 100%

Qualification: Matric from recognized university / Institute with driving licence of light commercial vehicle at least 3 years experience of driving a vehicle in a reputed organization. Age not more than 40 years.

The Chief Secretary to Govt., Haryana has observed vide letter No. 25/18/2005-4GSII dated 13.9.05 (Copy placed at Annexure 'A') that in most of the service rules of Group 'C' employees of the departments, provision exists for promotion of group 'D' and group 'C' employees to the post of Driver if he has valid driving licence to drive a Jeep / Car etc. and has at least five years service on a group 'D' or 'C' post. No maximum age for an employee to qualify for promotion under this Rule has been prescribed in the service rules of the departments.

The matter has been considered by the Govt. and it has been decided that the maximum age for an employee to qualify for promotion as Driver under the aforesaid Rules shall be restricted to 50 years. In addition he should have driving licence of driving cars and jeeps, which is at least 5 years old.

It has requested to take immediate necessary action to carry out necessary amendment in the relevant group 'C' service rules governing the post of Drivers of department wherever such a provision for promotion exists in the service rules.

Matter is placed before the Board of Directors of the Federation for consideration and adoption of the above said instructions of the Govt. in the Federation & amend the service rules accordingly.

241

103

ANNEXURE 'A'

From No. 25/18/2005-4GSH
To The Chief Secretary to Government Haryana.

1. All Heads of Departments in Haryana
2. Commissioner, Ambala, Hisar, Rohtak and Gurgaon Divisions.
3. The Registrar, Punjab & Haryana High Court.
4. All Deputy Commissioners and Sub Divisional Officers (Civil) in Haryana.
5. The Registrars, M.D.U. Rohtak/K.U. Kurukshetra/ Ctr. Charan Singh H.A.U. Hisar/ G.J.U. Hisar/ Ch. Devi Lal University (Sirsi).

Dated Chandigarh, the 13.9.2005

Subject: Promotional avenues to the Group 'C' and 'D' employees on the posts of Drivers.

Sir,

I am directed to address you on the subject noted above and to say that it has been observed that in most of the service rules of Group 'C' employees of the departments, provision exists for promotion of Group 'D' and Group 'C' employees to the post of Driver if he has a valid driving licence to drive a jeep/car etc. and has at least five years service on a Group 'D' or 'C' post. No maximum age for an employee to qualify for promotion under this rule has been prescribed in the service rules of the departments.

The matter has been considered by the Government and it has been decided that the maximum age for an employee to qualify for promotion as Driver under the aforesaid rules shall be restricted to 50 years. In addition, he should have driving licence of driving cars and jeeps which is at least 5 years old.

You are requested to take immediate necessary action to carry out necessary amendment in the relevant Group 'C' service rules governing the post of Drivers of your department, wherever such a provision for promotion exists in the service rules.

These instructions should be brought to the notice of all concerned for their information and strict compliance.

The receipt of this communication may kindly be acknowledged.

Yours faithfully,

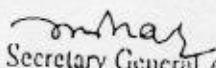
Deputy Secretary General Administration,
for Chief Secretary to Government Haryana.

A copy is forwarded to the following for information & necessary action:-

- 1) All the Financial Commissioner & Principal Secretary to Government, Haryana.
- 2) All the Administrative Secretaries to Government, Haryana.
- 3) Senior Special Private Secretaries/ Senior Private Secretaries/ Private Secretaries to Chief Minister / Ministers.

104

164

**HARYANA DAIRY DEVELOPMENT COOPERATIVE FEDERATION LTD.
BAY No.21-22, SAHAKARITA BHAWAN, SECTOR-2, PANCHKULA**

Ref. No. HDDCF/ Est/EA-2/2007/ 310-17

Dated: 12/4/07

To

1. The Chief Executive Officer
All the affiliated Milk Unions
2. The Manager,
SBTC, Rohtak
3. All Divisional Heads
HDDCF Hqrs. Panchkula

Sub:- Promotion avenues to group 'C' & 'D' employees on the post of Driver.

Sir,

The BoD of the Federation in its 144th meeting held on 13.2.2007 has taken the following decision in regard to the above matter:

"Approved as proposed with the stipulation that 75% posts of Drivers should be filled up by way of promotion and rest of the posts by way of direct recruitment. Rest of the Rules stand."

You are requested to take further necessary action in the matter accordingly.

Thanking you,

Yours faithfully,

3/8-19
12/4/07

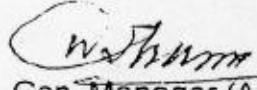
Asstt. Gen. Manager (Admn)
For Managing Director

- CC: 1. All Asstt. Manager/ EA-1 in Admn. Branch
2. ER-1, Admn. Branch HDDCF HQ PKL

Haryana Dairy Dev. Coop. Fed. Ltd
Bays No.21-22, Sec.2, Panchkula.
29 JUN 2007
HARYANA 1926

105

From

Commissioner & Secy. to Govt.
Cooperation Department.

To
urgent

Managing Director,
Haryana Dairy Development Cooperative Fed.
Ltd; Sector-2, Panchkula.

Memo No. 1303-C-6-2007/11826
Chandigarh, dated 28-6-07

Complaint against officers of Haryana Dairy
Development Coop. Fed. Ltd. regarding revision
of pay scales.

You are hereby directed to keep in abeyance
the matter regarding implementation of revised pay scales,
till such time the matter is finalized by the Govt.

By. *R. Parshad*
Supt. Coop.
for Commissioner & Secy. to Govt. Haryana.
Cooperation Department.

29/6
Sub:-
complaint
in
reg. to
pay scales
of officers
of Haryana Dairy
Development Coop. Fed. Ltd.
Sector-2, Panchkula.

From,

106

Registrar
Cooperative Societies, Haryana,
Panchkula.

Managing Director
Haryana Dairy Development Cooperative
Federation Ltd
Bay No. 21-22, Vita Bhawan, Sector -2
Panchkula

Memo No. /Milk/ 6417 Dated:- 23/6/08

Subject: - Amendment in Haryana Dairy Co-op. Staff Service Rules
regarding provision of Second Appeal - Clarification thereof.

Ref your letter No Estt/^{with}AM-3/PF-81/2008/1634 dated 10 Jun 2008. ^{224/C.}

It is clear that RCS is appellat authority in both the cases i.e ACR
matter & Penalties. All old cases will be monitored with as per new
amendment .

This is for your information and further action please.

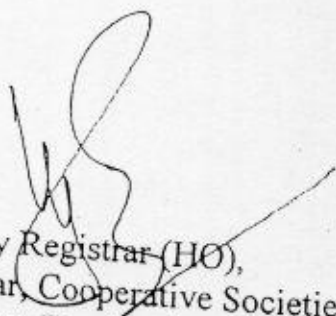
Deputy Registrar (HO),
For Registrar, Cooperative Societies,
Haryana, Panchkula. *Y*

23/6/08

From

Financial Commissioner and Principal Secretary to
Government, Haryana, Cooperation Department.

To

The Registrar,
Cooperative Societies, Haryana,
Panchkula.

Memo No. 1526-C-6-08/
Chandigarh, dated

172

Haryana Dairy Dev. Coop. Fed. Ltd. Bays No. 21-22, Sec. 2, Panchkula.
09 JAN 2009
RECEIPT No. 9924

Subject: Revision of Organisation Charts of Milk Producers Cooperative Unions and Haryana Dairy Development Cooperative Federation w.e.f. 1.4.2006.

Reference: Your Memo No. Milk-K-3-06/2386, dated 18.9.2008.

The matter regarding revision of Organisation Charts of Milk Producers Cooperative Unions and Haryana Dairy Development Cooperative Federation w.e.f. 1.4.2006 was under consideration of the Government. However, keeping in view of the latest policy of the department regarding applicability of Haryana Bureau of Public Enterprises the Government has decided to regularise the implementation of revised Organisational Charts and pay scale of the employees of HDDCF and Milk Unions except granting higher pay scales after changing the nomenclature of the posts of i) Director (Prod. & Projects)/Director (Mktg); ii) General Manager (Projects)/(General Manager Milk Plants/Project Officer and iii) Manager (A&F)/ Manager (P&M)/ Manager (Prod.) / Dairy Engineer/Mgr. (Seman Bank) / XEN to the posts of a) Chief General Manager b) General Manager c) Deputy General Manager / XEN which needs to be reviewed at Government level".

You are requested to ensure a strict compliance of the Government instructions in letter and spirit.

sdh -
Deputy Superintendent Cooperation,
For Financial Commissioner and Principal Secretary to
Government, Haryana, Cooperation Department.

Endst.No. 1526-C-6-08/ 163 Chandigarh, dated 6-1-09

A copy is forwarded to the Managing Director, Haryana Dairy Development Cooperative Federation Ltd., Sector-2, Panchkula for information and necessary action.

Chandee Shukla
Deputy Superintendent Cooperation,
For Financial Commissioner and Principal Secretary to
Government, Haryana, Cooperation Department.

BOD

HDDCF

Agenda No. 12/155/2009

Page No.

Grant of relaxation in experience for next promotion under New Organizational chart.

The new organizational chart was approved by the BOD of the Federation vide Agenda Item 18/139/05 in its 139th meeting held on 04/08/2005. As per provision in the organizational chart, the condition of 5 years experience was prescribed for promotion to the next post in different categories of posts.

It has been observed that majority of the officers/officials are on the verge of retirement and such employees are not eligible for promotion for want of prescribed experience. The employees who have been working in the organization for the last more than 20-30 years are deprived of their promotion to the next post before retirement for want of prescribed experience of 5 years. To mitigate their grievance it would be in the fitness of things if the condition of 5 years experience is relaxed suitably depending upon the capability of the officer/official who is considered fit for the promotion in the overall interest of the organization. This will also result in boosting the morale of the existing staff. It is also added here that if any post remain vacant for more than 3 years that is considered as abolished as per policy instructions issued by the Govt. A large number of posts are earmarked to be filled up by way of promotion in the Federation/ Milk Unions.

The matter is placed before the BOD of the Federation for consideration and approval please.

HARYANA DAIRY DEVELOPMENT COOPERATIVE FEDERATION LTD.
BAYS NO. 21-22, VITA BHAWAN, SECTOR-2, PANCHKULA

An Extract from the proceedings of 155th meeting of the Board of Directors of Haryana Dairy Development Co-operative Federation Ltd. held on 28TH AUG., 2009, at Bays No. 21-22 'vita Bhawan', Sector-2, Panchkula.

12/155/2009	Grant of Relaxation in Experience for Next Promotion under New Organization Chart.	After detailed discussion the proposal as per agenda was approved by the BOD.
13/155/2009	Request of Sh. Krishan Kumar Gupta, Advocate to increase his Retainership Fee.	After discussion the Board approved the following rates of fee in respect of all legal advisers engaged by the Federation. Rs. 5000/- as retainer ship fee per month and Rs. 11,000/- per case for High Court and Rs. 8000/- per case for Lower Court cases
14/155/2009	Regarding waiving off the condition of Computer Knowledge in the case of Plant Operator and Compressor Operator	Approved.

Endst. No. BOD: AM-3:155:2009: 5275 Dt. 14.10.09

A copy is forwarded to EA-2 HDDCF Ltd., Panchkula for information and necessary action.

He is requested to intimate the action taken on the proceedings within a period of 15 days positively.

Sudeshan
 Asstt. Manager (Admn.)
 For Managing Director.

110

**HDDCF
BOD AGENDA**

Agenda Item No. 14.1/155/2009

Page No.

**Regarding waiving off the condition of Computer knowledge
in the case of Plant Operator and Compressor Operator.**

The New Organizational Chart came into existence with effect from 1.04.2006 whereby an additional qualification "Must have a working knowledge of Computer including M.S.Office (i.e. M.S.Word, M.S.Excel, Power Point)" is prescribed for the posts of Plant Operator and Compressor Operator whereas these posts are of lower level technical nature and the candidates of the respective trade don't have such type of knowledge. Only I.T.I. certificate holder in the relevant field is required for these posts. Hence it would be appropriate to delete / waive off this additional qualification of computer knowledge for these categories.

Matter is placed before the Board of Directors for consideration and decision.

HARYANA DAIRY DEVELOPMENT COOPERATIVE FEDERATION LTD.
BAYS NO. 21-22, VITA BHAWAN, SECTOR-2, PANCHKULA

An Extract from the proceedings of 155th meeting of the Board of Directors of Haryana Dairy Development Co-operative Federation Ltd. held on 28TH AUG., 2009, at Bays No. 21-22 'vita Bhawan', Sector-2, Panchkula.

12/155/2009	Grant of Relaxation in Experience for Next Promotion under New Organization Chart.	After detailed discussion the proposal as per agenda was approved by the BOD.
-------------	--	---

13/155/2009	Request of Sh. Krishan Kumar Gupta, Advocate to increase his Retainership Fee.	After discussion the Board approved the following rates of fee in respect of all legal advisers engaged by the Federation. Rs. 5000/- as retainer ship fee per month and Rs. 11,000/- per case for High Court and Rs. 8000/- per case for Lower Court cases
-------------	--	--

✓ 14/155/2009	Regarding waiving off the condition of Computer Knowledge in the case of Plant Operator and Compressor Operator	Approved.
---------------	---	-----------

Endst. No. BOD: AM-3:155:2009: 5277 Dt. 14.10.09

A copy is forwarded to EA-2 HDDCF Ltd., Panchkula for information and necessary action.

He is requested to intimate the action taken on the proceedings within a period of 15 days positively.

Sudershan
 Asstt. Manager (Admn.)
 For Managing Director.

BOD HDDCF

Agenda item No:- 12/159/2070

Page no:

Subject:- Regarding Qualification prescribed for the post of Asstt Manger (Production).

While framing the new organizational chart the qualification for the post of Asstt. Manager (Production) for direct recruitments has been prescribed by the Fed is:

"Graduate in Dairying or food processing or Agri Science Marks 60% or above must have a working knowledge of computer including MS Office"

Recently the Milk Unions have recruited some Asstt. Manger (Production) through Haryana Staff Selection Commission having the qualification of Msc./Bsc. Agri Science. Now the Federation has received a communications from Milk Union Ambala (copy Annexed at 'A') that the new incumbent on joining were placed in production sections but they are not having the knowledge of processing of Milk and Milk products as a result Milk Union Ambala is facing difficulties in day to day working in processing of Milk and Milk products, hence the qualification of Agri Science for the post of Asstt Manager (Production) is not serving the purpose as they are not exposed to dairy processing during their Graduation Course which is needed for working at the post of Asstt. Manager (production).

Apart from above, the qualification for the post of AGM (production) is also same as Asstt. Manager (Production) which does not serve our pupose.

In view of the position explained above it would be appropriate that the qualification prescribed as graduate in Agriculture Science for the post of Asstt. Manager (Production) and AGM (Production) may be deleted from the organizational chart.

The matter is placed before the 'Board of Director' for consideration and decision.

HARYANA DAIRY DEVELOPMENT COOPERATIVE FEDERATION LTD.
BAYS NO. 21-22, VITA BHAWAN, SECTOR-2, PANCHKULA

An Extract from the proceedings of 159th meeting of the Board of Directors of Haryana Dairy Development Co-operative Federation Ltd. held on 21ST DECEMBER, 2010, at Bays No. 21-22 'vita Bhawan', Sector-2, Panchkula.

12/159/2010	Reg. Qualification Prescribed For The Post Of Assistant Manager (Production).	Approved.
-------------	---	-----------

Endst. No. BOD: AGM (Admn):159:2011/ 5694 Dt. 13/1/2011

A copy is forwarded to EA-2, HDDCF Ltd., Panchkula for information and necessary action.

He is requested to intimate the action taken on the proceedings within a period of 15 days positively.

Sedeshan
Asstt. Gen. Manager (Admn.)
For Managing Director.

109

114

From

Financial Commissioner & Principal Secretary to Govt.,
Haryana, Cooperation Department.

To

✓ The Managing Director,
Haryana Dairy Development Cooperative Federation Ltd
Panchkula.

dx?
9/4

Memo No. 422 - C-6-2010/ 4179
Chandigarh, dated the 8-4-10

M. Adh)
9/4
EAT

Subject:- Revision of Organization Charts of Milk Producers Cooperative Union
and Haryana Dairy Development Cooperative Federation w.e.f.
1-4-2006.

Ref:- Your office single file note dated 12-3-2010 & representation of Shri
R.K. Chugh, D.E. dated 1-4-2010

It is intimated that your request has been examined and found genuine. you are therefore, requested to correct misinterpretation, if any as promotion has never been stopped by the Government and same issue has also been incorporated in the query raised by the Finance Department vide U.O. letter dated 25.3.2010 and conveyed to you vide this department letter dated 30.3.2010. The requisite information desired by Finance Department may also be sent at the earliest so that this department may be able to take up the matter with Finance Department.

J. Pasheq
Superintendent,

for Financial Commissioner & Principal Secretary to Govt.
Haryana, Cooperation Department.



115

EPABX Nos: 2586487, 2585513
Email : vitaindia@gmail.com
Fax No : 2587527
Telegram : VITALITY

HARYANA DAIRY DEVELOPMENT COOPERATIVE FEDERATION LTD.
BAYS NO. 21-22, VITA BHAWAN, SECTOR-2, PANCHKULA

ORDER

In supersession of the orders dated 31.07.2009, issued vide Endst No. HDDCF/Admn/PFHQ/09/3281-92 dated 04.08.2009, the Pay Scales and Designations of the post of the officers in pre-revised Pay Scale of Rs. 10000-13900 and above will be as under :-

S. N.	Existing Pay Scale	Existing Post / Designation	New Pay scale after change of nomenclature	Changed / New nomenclature of post
1.	12000-16500	Director (Prod. & projects) / Director (Mktg.)	12000-16500	Chief Gen. Manager
2.	10000-15200	General Manager (Projects) / General Manager Milk Plants / Project Officer	10000-15200	General Manager
3.	10000-13900	Manager (A&F)/ Manager (P&M)/ Manager (Prod.)/ Dairy Engineer/ Mgr. (Semen Bank)	10000-13900	Dy. Gen. Manager
		XEN		XEN

2. These Scales are likely to be reviewed by the State Govt.
3. These orders will take effect from 1.04.2006.

Panchkula, dated
The, 15th April, 2010

V.S. KUNDU, IAS
MANAGING DIRECTOR

Endst.No. Estt/EA-II/Misc. 218/2Kx/ 337-348 Dated : 16-4-10

A copy for information and further necessary action is forwarded to:-

1. All CEOs, Milk Unions in the State of Haryana;
2. Manager, Mineral Mixture Plant & Training Centre, Rohtak;;
3. All Officers at Hqrs., Panchkula;
4. Drawing & Disbursing Officer, HDDCF Ltd., Panchkula;
5. All A.Ms (Admn.) / Dealing Hands, Estt. Br., HDDCF Ltd., Panchkula;
6. PA/MD; PA/CAO, HDDCF Ltd., Panchkula;
7. EA-2, Hqrs., for main file along with relevant noting portion.

Sudershan
Manager (Admn.)

For Managing Director

116

Haryana Dairy Dev. Coop. Ltd.
Bays No.21-72, Sec.2, Panchkula.
30 DEC 2010
RECEIPT No. 5006

प्रेषक

वित्तायुक्त एव प्रधान सचिव,
हरियाणा सरकार, सहकारिता विभाग ।

सेवा में,

रजिस्ट्रार सहकारी समितिया हरियाणा
पंचकुला ।

यादि क्रमांक 1294-सी-6-10/
चण्डीगढ़ दिनांक

विषय -

बाबत पद नाम बदलने, हरियाणा डेयरी विकास प्रसंग ।

संदर्भ

आपका पत्र क्रमांक 3/8/05/मिल्क/520 दिनांक 19-2-2010

विषयोक्त मामले में सूचित किया जाता है कि आपके उक्त पत्र के साथ प्राप्त प्रस्ताव
पर विचारोपरान्त असहमति प्रकट करते हुए मामला दाखिल दफतर कर दिया गया है ।

उप-अधीक्षक,

कृत : वित्तायुक्त एव प्रधान सचिव,
हरियाणा सरकार, सहकारिता विभाग ।

पृ० क्रमांक 1294 सी-6-10/1703 चण्डीगढ़ दिनांक 27-12-10
इसकी एक प्रति निदेशक हरियाणा डेयरी विकास प्रसंग पुचकुला को उनके
पत्र क्रमांक एच०डी०डी०सी०एफ०/प्रशा/ई०ए०-2010/2732 दिनांक 9-8-10 के संदर्भ
में सूचनार्थ एवं आवश्यक कार्यवाही हेतु प्रेषित है ।

उप-अधीक्षक,

कृत : वित्तायुक्त एव प्रधान सचिव,
हरियाणा सरकार, सहकारिता विभाग ।



EPABX Nos: 2586487, 2585513
Email hddcf1@hry.nic.in
Fax No : 0172-2587527
Telegram : VITALITY

HARYANA DAIRY DEVELOPMENT COOPERATIVE FEDERATION LTD.
Bay No.21-22, Vita Bhawan, Sector 2, Panchkula (Haryana)

Ref. No.HDDCF:Admn: AM-1/2011/

3607-13

Dated: 5/10/2011

The Chief Executive Officer
All affiliated Milk Unions in Haryana

The Manager,
Mineral Mixture Plant - cum - Training Centre
Rohtak

Subject:- Regarding Rectification in the Probation period of Group A B C & D
Employees of the Federation

Sir,

It is intimated that the captioned subject has been engaging the attention of the management from some time past. The Board of Directors of the Federation in its meeting held on 2.9.2011 deliberated over the issue vide agenda Item No. 9/161/2011 and decided to keep the probation period of Group A B C & D employees of Federation / Milk Unions as per Govt. pattern. Hence in view of above, clause No. 12.1 of "The Haryana Dairy Cooperative's Staff Service Rules, 1988" may be treated as amended to that extent. Copies of agenda No. 9/161/2011 and decision of the BOD of HDDCF are enclosed herewith. This is for your information and further necessary action accordingly.

Thanking you,

Yours faithfully,

Encl: As above.

3614-16
5/10/2011

Chief Admn. Officer
For Managing Director

Copy forwarded for information and necessary action :-

1. All Divisional Heads / Officers at Hqrs.Panchkula
2. AGM (Admn) / Manager (Admn) Hqrs.Panchkula
3. All Asstt. Manager (Admn) / Dealing Hands in Admn. Br. at Hqrs. Panchkula.

HDDCF BOD AGENDA

Agenda Item No. 9/161/2011

Regarding rectification in the probation period of Group A,B,C & D employees of the Federation.

There is a provision of probation as per clause 12.1 of The Haryana Dairy Cooperative's Staff Service Rules, 1988 as under :

"Persons appointed to any post in Group-A and B of the service shall remain on probation for a period of two years and in Group C and Group D of the service for a period of 6 months if appointed by direct appointment and one year if appointed by promotion."

From the perusal of the above probation clause in the service rules, there appears some ambiguity. The office view that the probation of direct appointee should be more than that of a promotee. It appears that this error has crept into the service rules inadvertently and needs to be rectified. To remove this error it would be appropriate that probation periods are kept as follow (which is also the prevalent practice, at present)

For Class A & B posts, direct appointees should be kept on probation of 2 years and those appointed by promotions should be kept on probation for 1 year.

For Class C & D posts, direct appointees should be kept on probation for 1 year and those promoted should be kept on probation for 6 months.

In view of the foregoing for the purpose of carrying out this rectification as well as ratification of the present practice, the matter is placed before the BOD of the HDDCF for consideration and approval.



EPABX Nos: 2586487, 2585513
Email : vitaindia@gmail.com
Fax No : 2587527
Telearam : VITALITY

HARYANA DAIRY DEVELOPMENT COOPERATIVE FEDERATION LTD.

BAYS NO. 21-22, VITA BHAWAN, SECTOR-2, PANCHKULA

Ref.No. Estt/EA-2/2014/ 5986-91

Dt. 29/1/14

All CEOs,
Milk Unions in the State of Haryana

Sub: Amendment in Haryana Dairy Co-operatives Staff Service Rules, 1988
(Amended)

Sir,

Please refer to the subject cited above.

It is informed that the the BoDs of HDDCF passed the resolution for making necessary amendments in change of nomenclature and qualification for the post of Clerks in its meeting held on 8.11.2013 vide Agenda Item No. 1/168/2013 in compliance of State Govt. letter No. 42/164/2008-3GSII dated 11.10.2013 as well as its substitution bearing same No. & date & proceedings of the meeting conveyed by the State Govt. vide U.O. No. 42/163/2013-5GSI dated 5.11.2013.

After the approval of the BoDs, the Registrar, Co-op. Societies, Haryana was requested for grant of approval in the above matter under section 37 of the Haryana Co-operative Societies Act, 1984 which has been granted by him vide his Orders Endst. No. 6 /2 / 2014 / Milk / 486-87 dated 15.01.2014. A copy of the approval accorded by the Registrar, Co-op. Societies, Haryana, is enclosed herewith for taking further necessary action.

Thanking you,

5992

29/1/14

Yours faithfully,

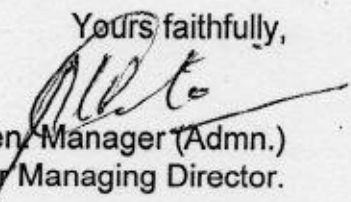
Asstt. Gen. Manager (Admn.)
For Managing Director.

CC:

- i) Dealing Assistants/Clerks in Admn. Br. At Hqrs.

TO BE SUBSTITUTED BEARING SAME NO. AND DATE

OFFICE OF THE REGISTRAR, COOPERATIVE SOCIETIES, HARYANA, PANCHKULA.

ORDER

Memo No. 6/2/2014/Milk/

Dated:

In exercise of the power conferred under Section 37 of the Haryana Cooperative Societies Act, 1984 and with the approval of the Haryana Board of Panchayats and approval of the additional Chief Secretary to Govt. Haryana, Cooperation Department vide their memo No. 2263-C-6-2013/15863 dated 31-12-2013, undersigned being the Registrar, Cooperative Societies, Haryana makes the following rules further to amend the HDDCF Staff Service Rules 1988.

1. These Rules may be called the HDDCF Staff Service Rules 1988 (Amended).
2. In the HDDCF Staff Service Rules 2014 (Amended) qualification for the employees for direct recruitment and promotion to the service in the Federation and its unions are as under:

Name of Service Rules	Existing Provisions of Federation & Union	Amended qualifications & Mode of Recruitment in Federation & Union.
Annexure B to Rule 4 of Haryana Dairy Cooperative Staff Service Rules, 1988 "Nature of Appointments".	<p>Clerk/Typist</p> <p>Direct = 50%</p> <p><u>Qualifications & Mode of Recruitment in the Federation.</u></p> <p>Graduate Marks 60% or above – Typing speed English 35 w.p.m. or Hindi 25 w.p.m. on computer. Must be proficient in operating computer. Age not more than 40 Years.</p> <p><u>Qualifications & Mode of Recruitment in the Union.</u></p> <p>Graduate Marks 60% or above – Typing speed English 35 w.p.m. or Hindi 25 w.p.m. on computer. Must be proficient in operating computer. Age not more than 40 Years.</p>	<p>Clerk:</p> <p>Direct = 50%</p> <p>Graduate. Marks 60% or above.</p> <p>State Eligibility Test in Computer Appreciation and Applications (SETC), along with a test in typing speed in accordance with syllabus as prescribed by the Government for the purpose, to be conducted by HARTRON/ any other agency as approved by the Government. The syllabus for SETC would contain Word processing, Internet Browsing and E-mail management only as prescribed by the Government and Typing speed 30 words per minute in English & 25 words per minute in Hindi converted with equivalent key depressions in both cases as the typing speed would be tested on computers.</p> <p>The State Eligibility Test in Computer Appreciation and Applications (SETC) shall be post requisite condition/ qualification and all the newly recruited / appointed Clerks shall</p>

have to qualify the State Eligibility Test in Computer Appreciation and Applications (SETC).

The candidate shall have to qualify the State Eligibility Test in Computer Appreciation and Applications (SETC) within the probation period of two years, extendable by one year in case of direct recruitment. The candidate shall not be entitled to earn any increment in his pay scale till he/she qualifies the said test failing which the services of such employees shall be dispensed with.

The Department would re-imburse the actual expenditure incurred by an employee on acquisition of requisite training/ skill-tests in Basic Computer Literacy, subject to the upper ceiling approved by the Government from time to time, on production of the requisite certificate of passing of the State Eligibility Test in Computer Appreciation and Applications (SETC). Further, the Government would also re-imburse the fees charged by HARTRON/ Authorised agency for conducting the proficiency test for only one attempt.

Candidates/ employees who have already passed the State Eligibility Test in Computer Appreciation and Applications (SETC) and the same are valid at the time of joining the service. The validity of possessing State Eligibility Test in Computer Appreciation and Applications (SETC) would be as decided by the Government from time to time.

The employees possessing the following qualifications are exempted from taking the State Eligibility Test in Computer Appreciation and Applications (SETC):-

i. M. Tech/ B. Tech (Computers),

Qualifications & Mode of Recruitment in the Federation.

Promotion = 50%

Out of category of Jamadar having 5 years experience as Jamadar and out of category of Peon having 10 years experience as Peon. Must at least be Matriculate. Further promotion will be subject to passing of a test.

No further recruitment to be made to the post of Jamadar.

Qualifications & Mode of Recruitment in the Union.

Promotion = 50%

Out of category of Peon/Gateman/Mali/Sweeper/Bull Attendant/Labourer/ Van Attendant having 10 years experience as Peon/Gateman/Mali/Sweeper/Bull Attendant/Labourer/ Van Attendant.

MCA, BCA or Diploma in Computers from the recognized Institutions e.g. Polytechnics;

ii. Basic Computer Literacy Certificate from any recognized centre established under the National Institute of Electronics & Information Technology (NIELIT) [erstwhile DOEACC Society];

iii. Haryana State – Certificate in Information Technology [HS-CIT] from the Authorized Learning Centres (ALCs) of the HKCL;

iv. Candidates/ employees who have already passed the SETC and the same are valid at the time of joining the service.

v. Physically disabled candidates.

However, these employees, with the exception of those mentioned under sub-para (v) above, shall be required to clear the type test being part of the State Eligibility Test in Computer Appreciation and Applications (SETC).

The test would be applicable from the date of issue of instructions of Government issued vide No.42/164/2008-3GS-II, dated 11th October, 2013.

Promotion= 50%

Minimum Educational Qualification for the post of Clerk is upgraded from matriculation to 10+2 level for promotion from Group-D employees.

The persons who are promoted to the post of Clerk shall also qualify the State Eligibility Test in Computer Appreciation and Applications (SETC) within the period of probation of one year extendable by one year failing which he/she will be reverted back.

	Must at least be Matriculate. Further promotion will be subject to passing of a test.	
Junior Store Keeper/ Asstt. Store Keeper/ Purchase Clerk.	Direct xxx xxx Promotion Out of Category of Store Attendant having 5 years experience as Store Attendant. Must at least be Matriculate.	Direct xxx xxx Promotion Out of Category of Store Attendant having 5 years experience as Store Attendant. Must at least be 10+2.
Rule 12 "Probation"	Persons appointed to any post in Group-A and B of the service shall remain on probation for a period of two years and in Group C and Group D of the service for a period of 6 months if appointed by direct appointment and one year if appointed by promotion. Provided that xxx xxx xxx"	The persons appointed to any post in Group-'A; 'B' 'C' and 'D' of the service shall remain on probation for a period of two years. The candidate shall have to qualify the State Eligibility Test in Computer Appreciation and Applications (SETC) within the probation period of two years extendable by one year in case of direct recruitment the candidate appointed against the aforesaid categories of posts in group 'C' shall not be entitled to earn in his pay scale till he/she the said test failing which the services of such employees shall be dispensed with. The persons who are promoted to the post of Clerk shall also qualify the State Eligibility Test in Computer Appreciation and Applications (SETC) to be conducted by Haryana State Electronic Development Corporation limited (HARTRON) or any other agency as approved by the Government within the period of probation of one year extendable by one year failing which he/ she will be reverted back. Provided that:- xxx xxx xxx"

Note: The amendments would be applicable from the date of approval of amendments and shall not effect the employee who were recruited/ appointed before the commencement of these Rules.

Place: Panchkula
Dated 14-01-2014

C.R. RANA
REGISTRAR, COOPERATIVE SOCIETIES,
HARYANA, PANCHKULA.

*Endst. No.6/2/2014/Milk/486-87

Dated: 15-01-2014.

A copy of the above is forwarded to the following:

1. Managing Director, The Haryana Dairy Development Cooperation Federation Ltd. Panchkula for necessary action.
2. Additional Chief Secretary to Govt. Haryana, Cooperation Department w.r.t. their letter Memo. No. 2263/C-7-2013/15863 dated 31-12-2013.

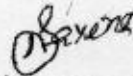

Deputy Registrar (Indl.)
for Registrar, Cooperative Societies,
Haryana, Panchkula.